



**Kugelhahn
Ball Valve**

M1

PVC-U

**DATENBLATT
DATASHEET**

2-way Ball Valve M1

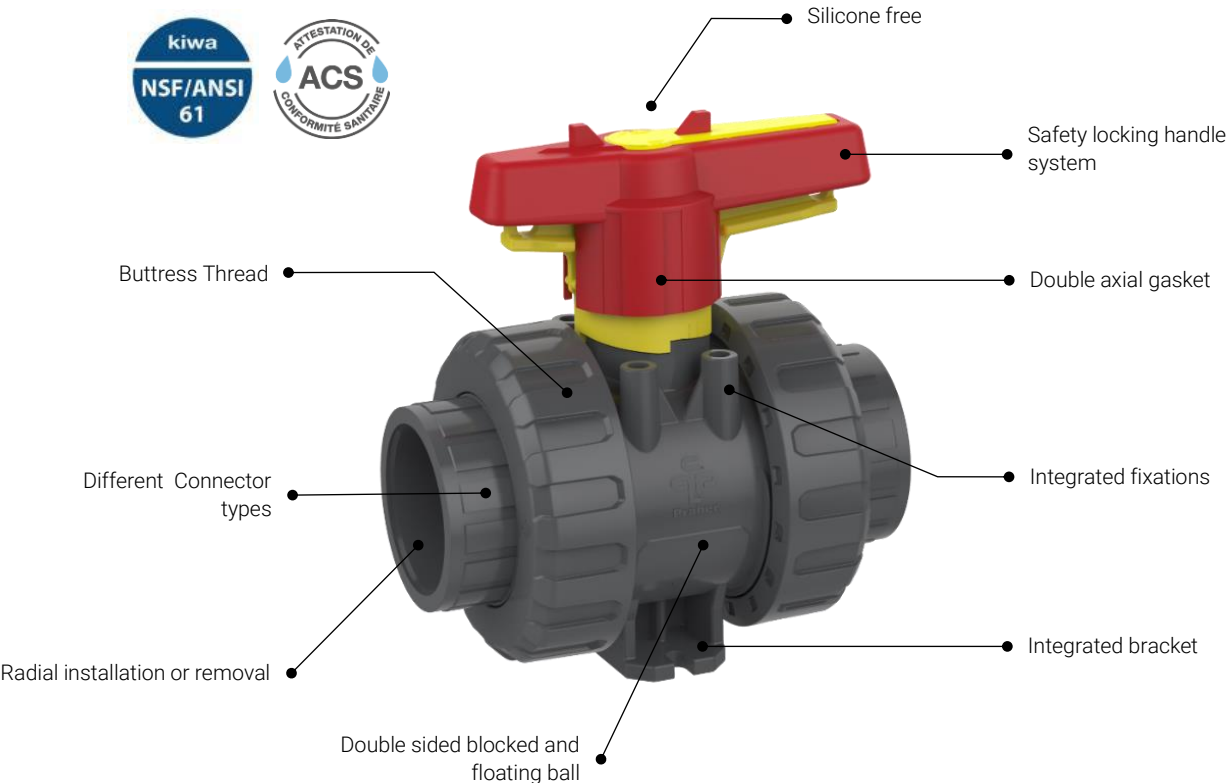

Overview

General

Material	Body material Seal material Ball seating joint	PVC-U EPDM / FPM PTFE
Dimensions	DN10 – DN80 d16 – d110 3/8" – 4"	
Connector types	Solvent socket Solvent spigot Threaded socket PE fusion socket PE fusion spigot PE fusion spigot long Fix flange Backing flange	metric / ASTM metric BSP / NPT metric metric metric DIN / ANSI / JIS DIN
Operating pressure	DN10 – DN80 d110 DN10 – DN80 d110 Backing flange	PN16 PN10

Range summery

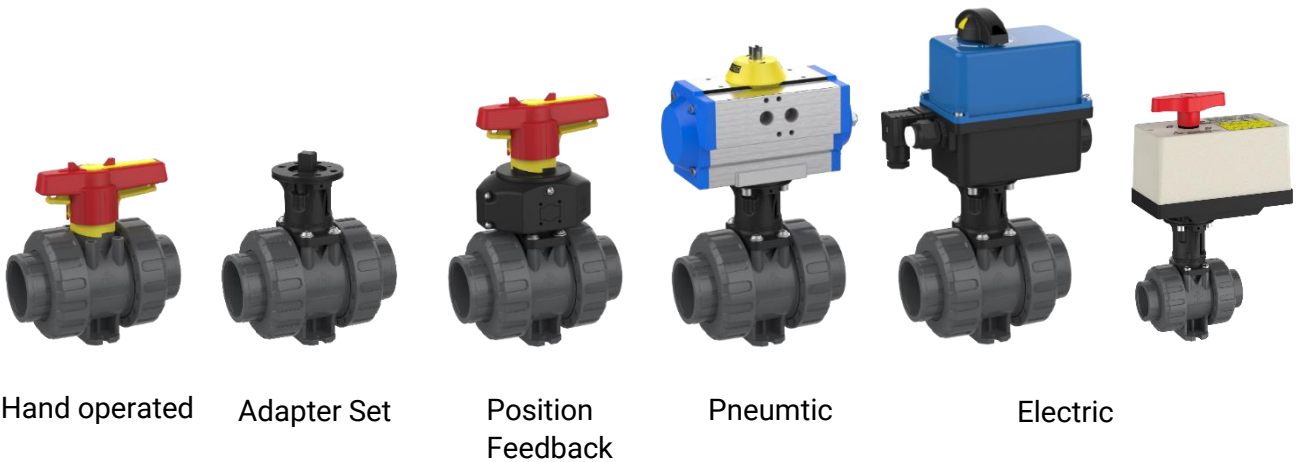







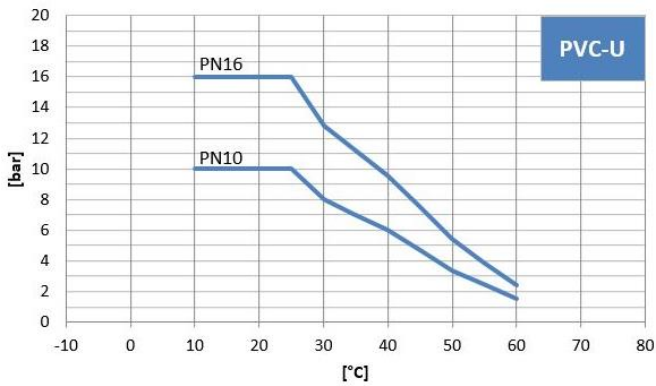

Table of contents

	technical data	page 5
	2W ball valve hand operated	page 6
	2W ball valve adapter set	page 10
	2W ball valve position feedback	page 15
	2W ball valve electric EO 510	page 21
	2W ball valve electric EO ER	page 25
	2W ball valve pneumatic	page 31
	accessories / spare parts	page 40

Technical data

Pressure – temperature – diagram



Torque at the shaft

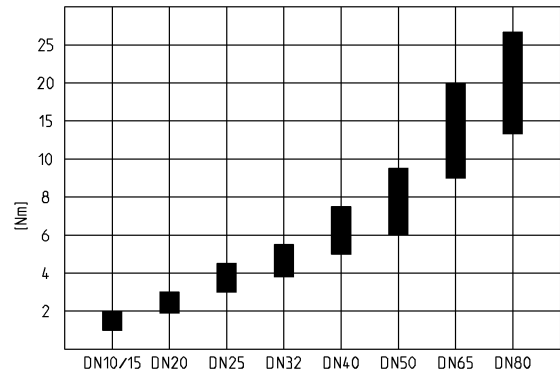

The values of the pressure-temperature-diagram are based on a service life of 25 years at static pressure load and apply to water or water-like media.

Flow rate – pressure loss

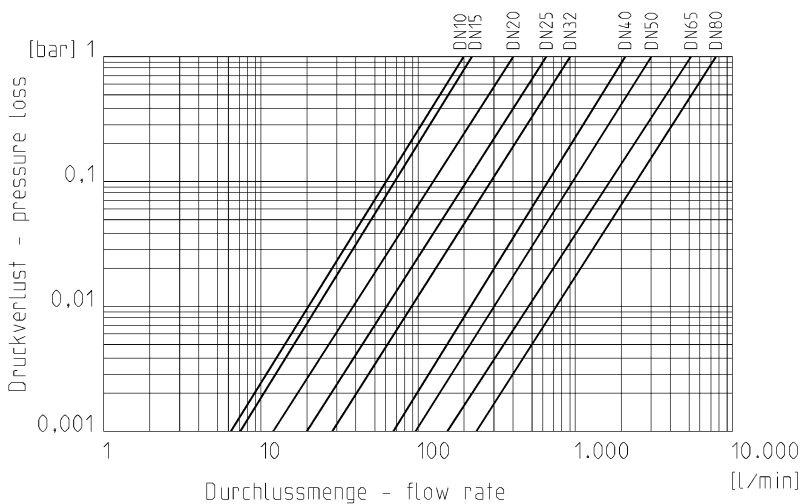

Flow characteristics

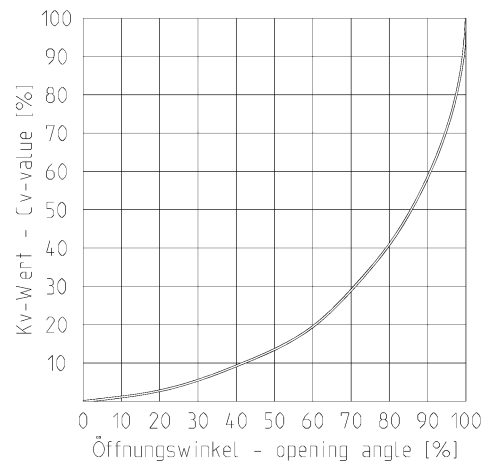

Cv-value-table

pressure loss	DN10 d16	DN15 d20	DN20 d25	DN25 d32	DN32 d40	DN40 d50	DN50 d63	DN65 d75	DN80 d90	DN80 d110
0,001 bar	6,2	7,1	12,6	19,9	28,4	67	94,8	162,8	240,3	240,3
1,0 bar	198	225	400	630	900	2120	3000	5150	7600	7600

specification in l/min (PN16 pipe)

Dimensions hand operated

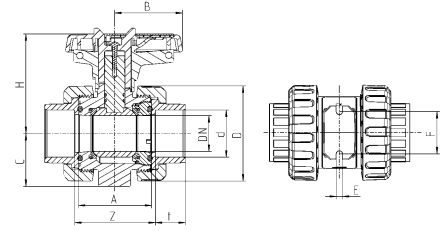

Connector type

PVC-U solvent socket metric / ASTM (dimensions in mm)

DN	10	15	20	25	32	40	50	65	80	80
d	16	20	25	32	40	50	63	75	90	110
inch	3/8"	1/2"	3/4"	1"	1 1/4"	1 1/2"	2"	2 1/2"	3"	4"
A	45	45	53,5	54	62	78	87	111,5	135,5	135,5
B	39,5	39,5	51	51	63,5	72	84	110	132	132
C	33	33	40	43	51	56	64	85	100	100
D	55,5	55,5	62	70	84	101	115	149	182	182
E	5,5	5,5	5,5	6,5	6,5	6,5	6,5	8,3	10,3	10,3
F	34	34	36	38	40	45	50	65	80	80
H	70,5	70,5	77	79,5	98	105,5	114	142	153	153
t	16	16,5	19,5	23	26,5	31,5	38,5	44,5	56,5	61
Z	51	50	59,5	60	68,5	86	98	122	152,5	162
PN	16	16	16	16	16	16	16	16	16	16

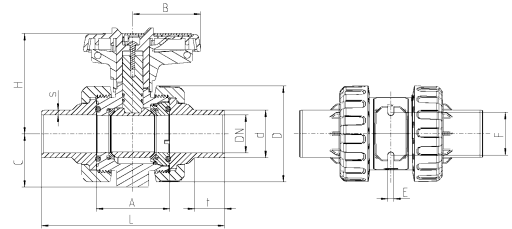

Connector type

PVC-U solvent spigot metric (dimensions in mm)

DN	10	15	20	25	32	40	50	65	80	80
d	16	20	25	32	40	50	63	75	90	110
A	45	45	53,5	54	62	78	87	111,5	135,5	135,5
B	39,5	39,5	51	51	63,5	72	84	110	132	132
C	33	33	40	43	51	56	64	85	100	100
D	55,5	55,5	62	70	84	101	115	149	182	182
E	5,5	5,5	5,5	6,5	6,5	6,5	6,5	8,3	10,3	10,3
F	34	34	36	38	40	45	50	65	80	80
H	70,5	70,5	77	79,5	98	105,5	114	142	153	153
L	98	123,5	143,5	153,5	173,5	194	223	259,5	297	314,5
s	2,8	2	2,5	3,5	4	5	6,5	6	6,7	8,1
t	17	17	20,5	23,5	27	32	40	45	54	64,5
PN	16	16	16	16	16	16	16	16	16	16

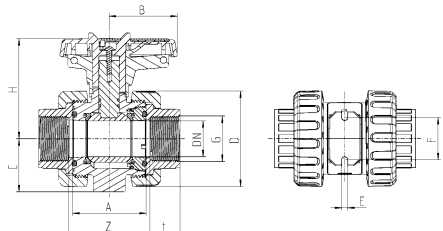

Connector type

PVC-U threaded socket BSP / NPT (up to DN50) (dimensions in mm)

DN	10	15	20	25	32	40	50	65	80	80
inch	3/8"	1/2"	3/4"	1"	1 1/4"	1 1/2"	2"	2 1/2"	3"	4"
A	45	45	53,5	54	62	78	87	111,5	135,5	135,5
B	39,5	39,5	51	51	63,5	72	84	110	132	132
C	33	33	40	43	51	56	64	85	100	100
D	55,5	55,5	62	70	84	101	115	149	182	182
E	5,5	5,5	5,5	6,5	6,5	6,5	6,5	8,3	10,3	10,3
F	34	34	36	38	40	45	50	65	80	80
H	70,5	70,5	77	79,5	98	105,5	114	142	153	153
t	17	17	19,5	23	26	31,5	38,5	44	55	61
Z	51	50	59,5	60	68,5	86	98	122	152,5	162
PN	16	16	16	16	16	16	16	16	16	10

Dimensions hand operated

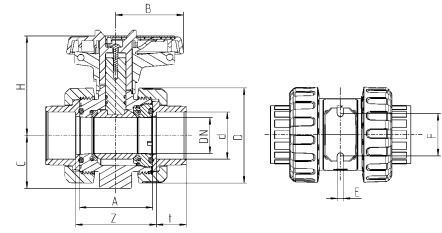

Connector type

PE fusion socket metric (dimensions in mm)

DN	10	15	20	25	32	40	50
d	16	20	25	32	40	50	63
A	45	45	53,5	54	62	78	87
B	39,5	39,5	51	51	63,5	72	84
C	33	33	40	43	51	56	64
D	55,5	55,5	62	70	84	101	115
E	5,5	5,5	5,5	6,5	6,5	6,5	6,5
F	34	34	36	38	40	45	50
H	70,5	70,5	77	79,5	98	105,5	114
t	14,5	16	17	19	21,5	25	29,5
Z	52,5	50	62	64,5	75	97	110,5
PN	16	16	16	16	16	16	16

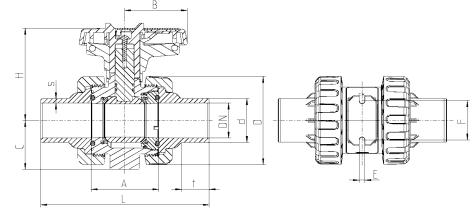

Connector type

PE fusion spigot metric (dimensions in mm)

DN	10	15	20	25	32	40	50	65	80	80
d	16	20	25	32	40	50	63	75	90	110
A	45	45	53,5	54	62	78	87	111,5	135,5	135,5
B	39,5	39,5	51	51	63,5	72	84	110	132	132
C	33	33	40	43	51	56	64	85	100	100
D	55,5	55,5	62	70	84	101	115	149	182	182
E	5,5	5,5	5,5	6,5	6,5	6,5	6,5	8,3	10,3	10,3
F	34	34	36	38	40	45	50	65	80	80
H	70,5	70,5	77	79,5	98	105,5	114	142	153	153
L	97,5	107	128,5	135,5	155	181	206,5	227	265,5	295,5
s	1,8	1,9	2,3	2,9	3,7	4,6	5,8	6,8	8,2	10
t	12,5	13	15	18	20	26	30	32	30	40
PN	16	16	16	16	16	16	16	16	16	16

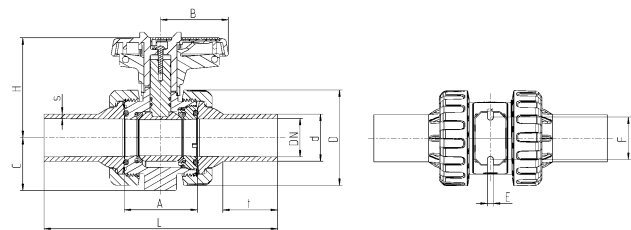

Connector type

PE fusion spigot long metric

(dimensions in mm)

DN	15	20	25	32	40	50	65	80	80
d	20	25	32	40	50	63	75	90	110
A	45	53,5	54	62	78	87	111,5	135,5	135,5
B	39,5	51	51	63,5	72	84	110	132	132
C	33	40	43	51	56	64	85	100	100
D	55,5	62	70	84	101	115	149	182	182
E	5,5	5,5	6,5	6,5	6,5	6,5	8,3	10,3	10,3
F	34	36	38	40	45	50	65	80	80
H	70,5	77	79,5	98	105,5	114	142	153	153
L	171	192,5	200,5	221	248	273	358,5	414	405,5
s	3	3	3	3,7	4,6	5,8	6,8	8,2	10
t	45,5	46,5	50	54,5	58	63	85	99	95
PN	16	16	16	16	16	16	16	16	16

Dimensions hand operated

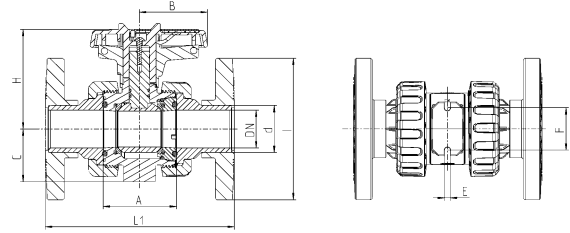

Connector type

PVC-U fix flange DIN-ANSI-JIS

(dimensions in mm)

DN	15	20	25	32	40	50	65	80	80
d	20	25	32	40	50	63	75	90	110
A	45	53,5	54	62	78	87	111,5	135,5	135,5
B	39,5	51	51	63,5	72	84	110	132	132
C	33	40	43	51	56	64	85	100	100
E	5,5	5,5	6,5	6,5	6,5	6,5	8,3	10,3	10,3
F	34	36	38	40	45	50	65	80	80
H	70,5	77	79,5	98	105,5	114	142	153	153
I	97	105	125	140	150	165	185	200	229
L1	130	150	160	180	200	230	266	307,5	324,5
PN	16	16	16	16	16	16	16	16	16

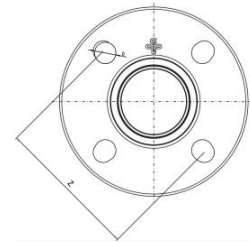

Connector type

fix flange DIN-ANSI-JIS

(dimensions in mm)

Standard	DN	15	20	25	32	40	50	65	80	80
	d	20	25	32	40	50	63	75	90	110
	inch	1/2"	3/4"	1"	1 1/4"	1 1/2"	2"	2 1/2"	3"	4"
DIN 2501	b	14	14	14	18	18	18	18	18	18
	Z	65	75	85	100	110	125	145	160	180
ANSI Class 150	b	15,5	15,5	15,5	15,5	15,5	19	19	19	19
	Z	60,3	69,8	79,3	89	98,5	120,6	139,7	152,4	190,5
JIS 10 k	b	15	15	19	19	19	19	19	19	19
	Z	70	75	90	100	105	120	140	150	175

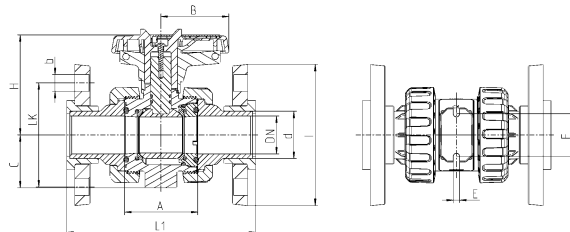

Connector type

PVC-U backing flange DIN

(dimensions in mm)

DN	15	20	25	32	40	50	65	80	80
d	20	25	32	40	50	63	75	90	110
A	45	53,5	54	62	78	87	111,5	135,5	135,5
B	39,5	51	51	63,5	72	84	110	132	132
b	14	14	14	18	18	18	18	18	18
C	33	40	43	51	56	64	85	100	100
E	5,5	5,5	6,5	6,5	6,5	6,5	8,3	10,3	10,3
F	34	36	38	40	45	50	65	80	80
H	70,5	77	79,5	98	105,5	114	142	153	153
I	97	105	125	140	150	165	185	200	229
L1	129,5	149,5	159,5	178,5	200	228,5	265,5	308	325
LK	65	75	85	100	110	125	145	160	180
PN	10	10	10	10	10	10	10	10	10

Exploded drawing hand operated

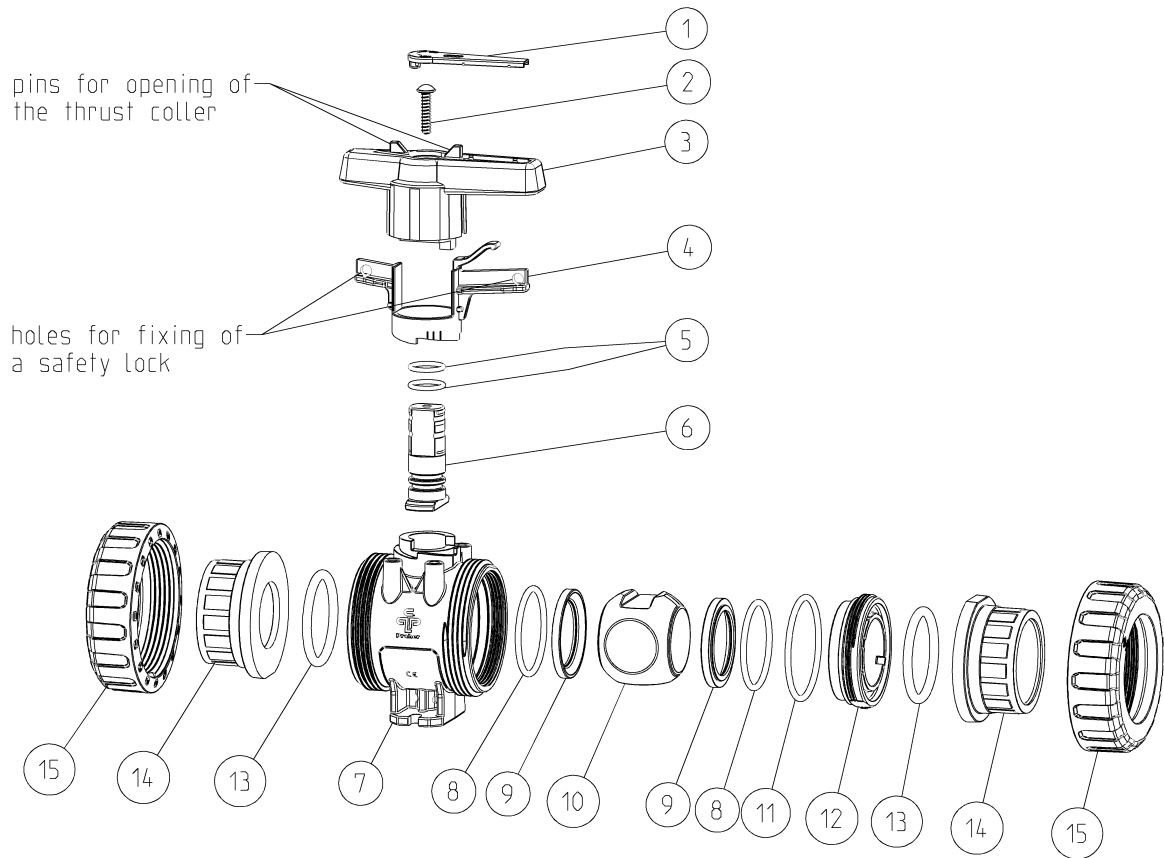

No.	Description	Material
01.	Labeling plate	PBT
02.	Screw	A2
03.	Handle	PP-GF
04.	Spring loaded locking sleeve	PBT
05.	O-ring	EPDM / FPM
06.	Shaft	PVC-U
07.	Body	PVC-U
08.	O-ring	EPDM / FPM
09.	Ball seating joint	PTFE
10.	Ball	PVC-U
11.	O-ring	EPDM / FPM
12.	Thrust collar	PVC-U
13.	O-ring	EPDM / FPM
14.	Connector types	
	Solvent socket /-spigot	PVC-U
	Threaded socket	PVC-U
	Fusion socket /-spigot	PE100
	Flange	PVC-U
15.	Union nut	PVC-U

Dimensions adapter set

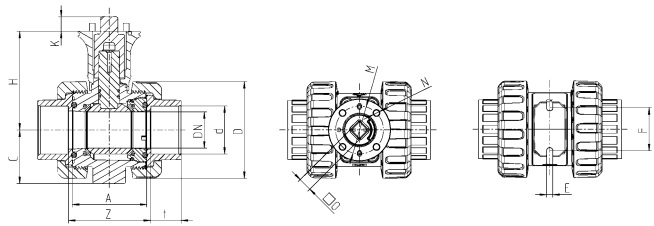

Connector type

PVC-U solvent socket metric / ASTM

(dimensions in mm)

DN	10	15	20	25	32	40	50	65	80	80
d	16	20	25	32	40	50	63	75	90	110
inch	3/8"	1/2"	3/4"	1"	1 1/4"	1 1/2"	2"	2 1/2"	3"	4"
ISO flange	F04	F04	F04	F04	F05	F05	F05	F07	F07	F07
A	45	45	53,5	54	62	78	87	111,5	135,5	135,5
C	33	33	40	43	51	56	64	85	100	100
D	55,5	55,5	62	70	84	101	115	149	182	182
E	5,5	5,5	5,5	6,5	6,5	6,5	6,5	8,3	10,3	10,3
F	34	34	36	38	40	45	50	65	80	80
H	80	80	85,5	88	97	103	109,5	136,5	159,5	159,5
K	11	11	11	11	15	15	15	18	18	18
M	42	42	42	42	50	50	50	70	70	70
N	5,5	5,5	5,5	5,5	6,5	6,5	6,5	8,5	8,5	8,5
O	11	11	11	11	14	14	14	17	17	17
t	16	16,5	19,5	23	26,5	31,5	38,5	44,5	56,5	61
Z	51	50	59,5	60	68,5	86	98	122	152,5	162
PN	16	16	16	16	16	16	16	16	16	16

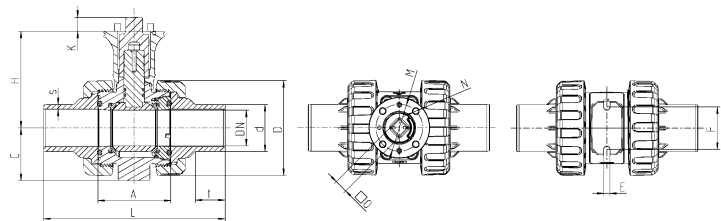

Connector type

PVC-U solvent spigot metric

(dimensions in mm)

DN	10	15	20	25	32	40	50
d	16	20	25	32	40	50	63
ISO flange	F04	F04	F04	F04	F05	F05	F05
A	45	45	53,5	54	62	78	87
C	33	33	40	43	51	56	64
D	55,5	55,5	62	70	84	101	115
E	5,5	5,5	5,5	6,5	6,5	6,5	6,5
F	34	34	36	38	40	45	50
H	80	80	85,5	88	97	103	109,5
K	11	11	11	11	15	15	15
L	98	123,5	143,5	153,5	173,5	194	223
M	42	42	42	42	50	50	50
N	5,5	5,5	5,5	5,5	6,5	6,5	6,5
O	11	11	11	11	14	14	14
s	2,8	2	2,5	3,5	4	5	6,5
t	17	17	20,5	23,5	27	32	40
PN	16	16	16	16	16	16	16

Dimensions adapter set

Connector type

PVC-U threaded socket BSP / NPT

(dimensions in mm)

DN	10	15	20	25	32	40	50
inch	3/8"	1/2"	3/4"	1"	1 1/4"	1 1/2"	2"
ISO flange	F04	F04	F04	F04	F05	F05	F05
A	45	45	53,5	54	62	78	87
C	33	33	40	43	51	56	64
D	55,5	55,5	62	70	84	101	115
E	5,5	5,5	5,5	6,5	6,5	6,5	6,5
F	34	34	36	38	40	45	50
H	80	80	85,5	88	97	103	109,5
K	11	11	11	11	15	15	15
M	42	42	42	42	50	50	50
N	5,5	5,5	5,5	5,5	6,5	6,5	6,5
O	11	11	11	11	14	14	14
t	17	17	19,5	23	26	31,5	38,5
Z	51	50	59,5	60	68,5	86	98
PN	16	16	16	16	16	16	16

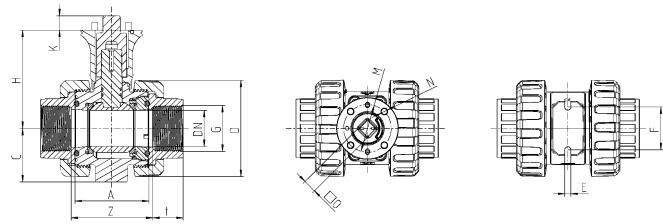

Connector type

PE fusion socket metric

(dimensions in mm)

DN	10	15	20	25	32	40	50
d	16	20	25	32	40	50	63
ISO flange	F04	F04	F04	F04	F05	F05	F05
A	45	45	53,5	54	62	78	87
C	33	33	40	43	51	56	64
D	55,5	55,5	62	70	84	101	115
E	5,5	5,5	5,5	6,5	6,5	6,5	6,5
F	34	34	36	38	40	45	50
H	80	80	85,5	88	97	103	109,5
K	11	11	11	11	15	15	15
M	42	42	42	42	50	50	50
N	5,5	5,5	5,5	5,5	6,5	6,5	6,5
O	11	11	11	11	14	14	14
t	14,5	16	17	19	21,5	25	29,5
Z	52,5	50	62	64,5	75	97	110,5
PN	16	16	16	16	16	16	16

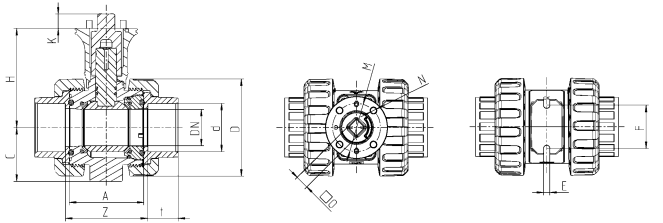

Dimensions adapter set

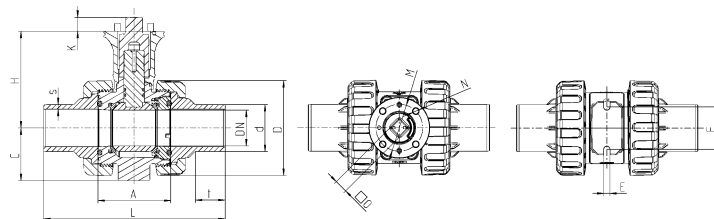

Connector type

PE fusion spigot metric

(dimensions in mm)

DN	10	15	20	25	32	40	50
d	16	20	25	32	40	50	63
ISO flange	F04	F04	F04	F04	F05	F05	F05
A	45	45	53,5	54	62	78	87
C	33	33	40	43	51	56	64
D	55,5	55,5	62	70	84	101	115
E	5,5	5,5	5,5	6,5	6,5	6,5	6,5
F	34	34	36	38	40	45	50
H	80	80	85,5	88	97	103	109,5
K	11	11	11	11	15	15	15
M	42	42	42	42	50	50	50
N	5,5	5,5	5,5	5,5	6,5	6,5	6,5
O	11	11	11	11	14	14	14
L	97,5	107	128,5	135,5	155	181	206,5
s	1,8	1,9	2,3	2,9	3,7	4,6	5,8
t	12,5	13	15	18	20	26	30
PN	16	16	16	16	16	16	16

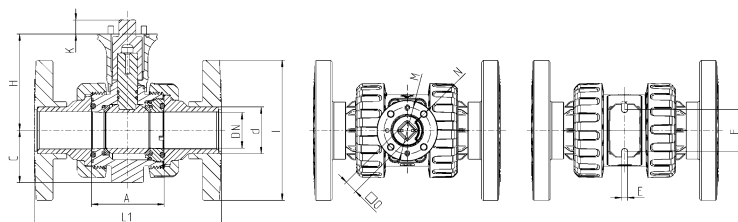

Connector type

PVC-U fix flange DIN-ANSI-JIS

(dimensions in mm)

DN	15	20	25	32	40	50	65	80	80
d	20	25	32	40	50	63	75	90	110
ISO flange	F04	F04	F04	F05	F05	F05	F07	F07	F07
A	45	53,5	54	62	78	87	111,5	135,5	135,5
C	33	40	43	51	56	64	85	100	100
E	5,5	5,5	6,5	6,5	6,5	6,5	8,3	10,3	10,3
F	34	36	38	40	45	50	65	80	80
H	80	85,5	88	97	103	109,5	136,5	159,5	159,5
I	97	105	125	140	150	165	185	200	229
K	11	11	11	15	15	15	18	18	18
L1	130	150	160	180	200	230	266	307,5	324,5
M	42	42	42	50	50	50	70	70	70
N	5,5	5,5	5,5	6,5	6,5	6,5	8,5	8,5	8,5
O	11	11	11	14	14	14	17	17	17
PN	16	16	16	16	16	16	16	16	16

Dimensions adapter set

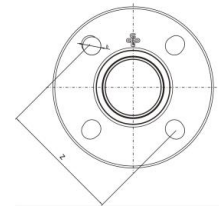

Connector type fix flange DIN-ANSI-JIS (dimensions in mm)

Standard	DN	15	20	25	32	40	50	65	80	80
	d	20	25	32	40	50	63	75	90	110
	inch	1/2"	3/4"	1"	1 1/4"	1 1/2"	2"	2 1/2"	3"	4"
DIN 2501	b	14	14	14	18	18	18	18	18	18
	Z	65	75	85	100	110	125	145	160	180
ANSI Class 150	b	15,5	15,5	15,5	15,5	15,5	19	19	19	19
	Z	60,3	69,8	79,3	89	98,5	120,6	139,7	152,4	190,5
JIS 10 k	b	15	15	19	19	19	19	19	19	19
	Z	70	75	90	100	105	120	140	150	175

Connector type PVC-U backing flange DIN (dimensions in mm)

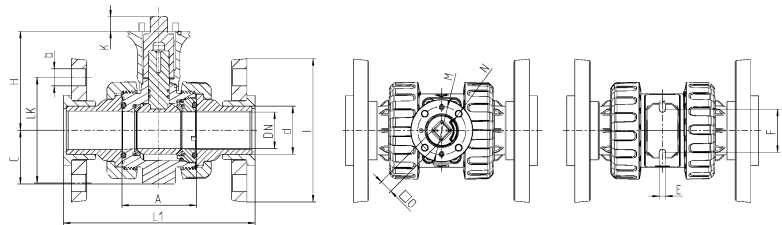

DN	15	20	25	32	40	50	65	80	80
d	20	25	32	40	50	63	75	90	110
ISO flange	F04	F04	F04	F05	F05	F05	F07	F07	F07
A	45	53,5	54	62	78	87	111,5	135,5	135,5
b	14	14	14	18	18	18	18	18	18
C	33	40	43	51	56	64	85	100	100
E	5,5	5,5	6,5	6,5	6,5	6,5	8,3	10,3	10,3
F	34	36	38	40	45	50	65	80	80
H	80	85,5	88	97	103	109,5	136,5	159,5	159,5
I	97	105	125	140	150	165	185	200	229
K	11	11	11	15	15	15	18	18	18
L1	129,5	149,5	159,5	178,5	200	228,5	265,5	308	325
M	42	42	42	50	50	50	70	70	70
N	5,5	5,5	5,5	6,5	6,5	6,5	8,5	8,5	8,5
O	11	11	11	14	14	14	17	17	17
LK	65	75	85	100	110	125	145	160	180
PN	10	10	10	10	10	10	10	10	10

Exploded drawing adapter set

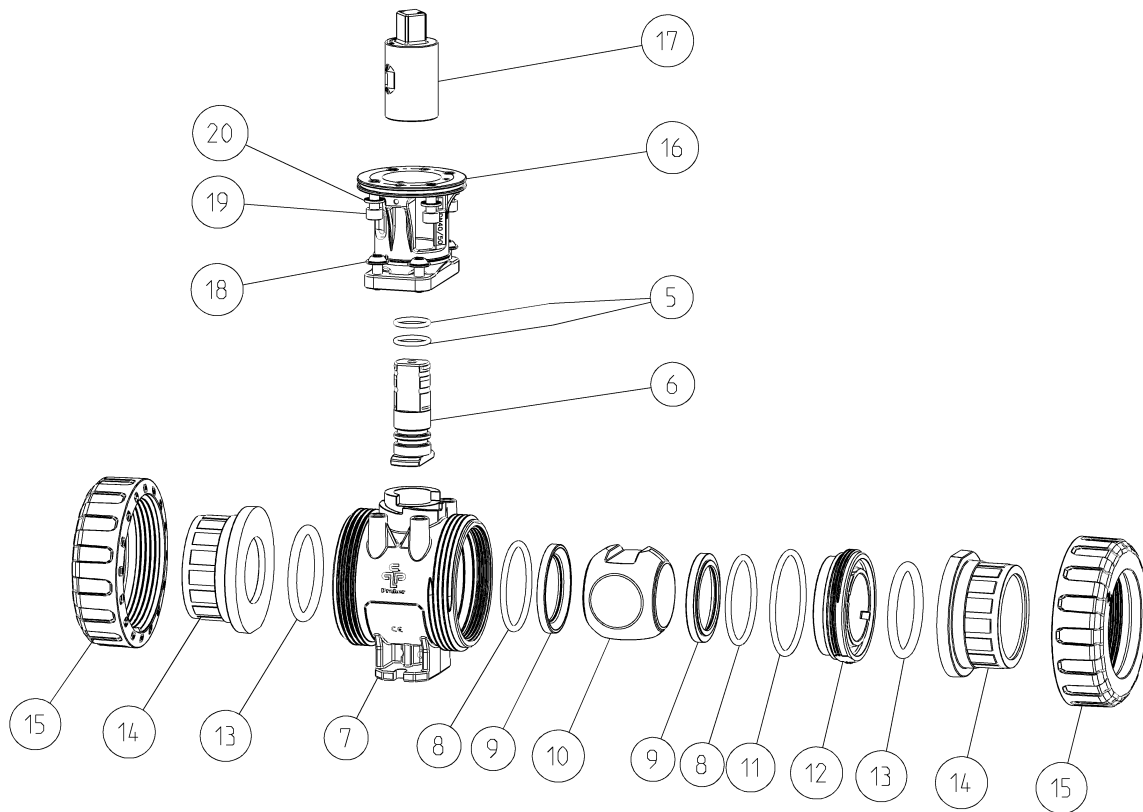

No.	Description	Material
05.	O-ring	EPDM / FPM
06.	Shaft	PVC-U
07.	Body	PVC-U
08.	O-ring	EPDM / FPM
09.	Ball seating joint	PTFE
10.	Ball	PVC-U
11.	O-ring	EPDM / FPM
12.	Thrust collar	PVC-U
13.	O-ring	EPDM / FPM
14.	Connector types solvent socket /-spigot Threaded socket Fusion socket /-spigot Flange	PVC-U PVC-U PE100 PVC-U
15.	Union nut	PVC-U
16.	Bracket	PA-GF
17.	Coupling shaft	PA-GF
18.	Screw	A2
19.	Screw	A4
20.	Toothed washer	A2 / A4 from DN65

Dimensions position feedback

Connector type

PVC-U solvent socket metric/ASTM (up to DN50)

(dimensions in mm)

DN	10	15	20	25	32	40	50	65	80	80
d	16	20	25	32	40	50	63	75	90	110
inch	3/8"	1/2"	3/4"	1"	1 1/4"	1 1/2"	2"	2 1/2"	3"	4"
A	45	45	53,5	54	62	78	87	111,5	135,5	135,5
B	39,5	39,5	51	51	63,5	72	84	110	132	132
C	33	33	40	43	51	56	64	85	100	100
D	55,5	55,5	62	70	84	101	115	149	182	182
E	5,5	5,5	5,5	6,5	6,5	6,5	6,5	8,3	10,3	10,3
F	34	34	36	38	40	45	50	65	80	80
H	126	126	137	139,5	159,5	167	175,5	213	238	238
P	98	98	102	102	105	105	105	116	116	116
Q	64	64	64	64	74	74	74	99	99	99
R	70	70	70	70	75	75	75	88	88	88
t	16	16,5	19,5	23	26,5	31,5	38,5	44,5	56,5	61
Z	51	50	59,5	60	68,5	86	98	122	152,5	162
PN	16	16	16	16	16	16	16	16	16	16

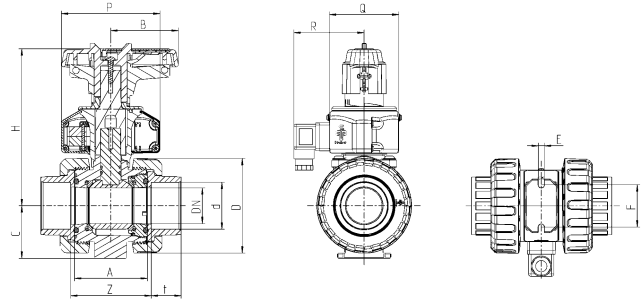

Connector type

PVC-U solvent spigot metrisch

(dimensions in mm)

DN	10	15	20	25	32	40	50
d	16	20	25	32	40	50	63
A	45	45	53,5	54	62	78	87
B	39,5	39,5	51	51	63,5	72	84
C	33	33	40	43	51	56	64
D	55,5	55,5	62	70	84	101	115
E	5,5	5,5	5,5	6,5	6,5	6,5	6,5
F	34	34	36	38	40	45	50
H	126	126	137	139,5	159,5	167	175,5
L	98	123,5	143,5	153,5	173,5	194	223
P	98	98	102	102	105	105	105
Q	64	64	64	64	74	74	74
R	70	70	70	70	75	75	75
s	2,8	2	2,5	3,5	4	5	6,5
t	17	17	20,5	23,5	27	32	40
PN	16	16	16	16	16	16	16

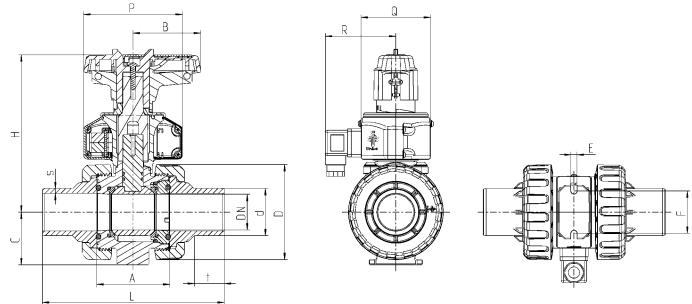

Dimensions position feedback

Connector type

PVC-U threaded socket BSP / NPT

(dimensions in mm)

DN	10	15	20	25	32	40	50
inch	3/8"	1/2"	3/4"	1"	1 1/4"	1 1/2"	2"
A	45	45	53,5	54	62	78	87
B	39,5	39,5	51	51	63,5	72	84
C	33	33	40	43	51	56	64
D	55,5	55,5	62	70	84	101	115
E	5,5	5,5	5,5	6,5	6,5	6,5	6,5
F	34	34	36	38	40	45	50
H	126	126	137	139,5	159,5	167	175,5
P	98	98	102	102	105	105	105
Q	64	64	64	64	74	74	74
R	70	70	70	70	75	75	75
t	17	17	19,5	23	26	31,5	38,5
Z	51	50	59,5	60	68,5	86	98
PN	16	16	16	16	16	16	16

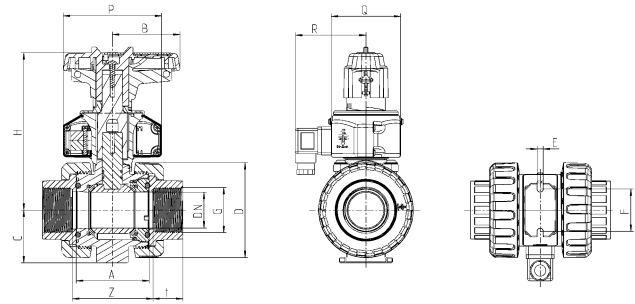

Connector type

PE fusion socket metric

(dimensions in mm)

DN	10	15	20	25	32	40	50
d	16	20	25	32	40	50	63
A	45	45	53,5	54	62	78	87
B	39,5	39,5	51	51	63,5	72	84
C	33	33	40	43	51	56	64
D	55,5	55,5	62	70	84	101	115
E	5,5	5,5	5,5	6,5	6,5	6,5	6,5
F	34	34	36	38	40	45	50
H	126	126	137	139,5	159,5	167	175,5
P	98	98	102	102	105	105	105
Q	64	64	64	64	74	74	74
R	70	70	70	70	75	75	75
t	14,5	16	17	19	21,5	25	29,5
Z	52,5	50	62	64,5	75	97	110,5
PN	16	16	16	16	16	16	16

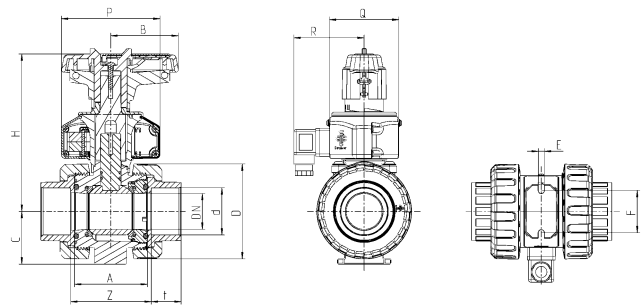

Dimensions position feedback

Connector type

PE fusion spigot metric

(dimensions in mm)

DN	10	15	20	25	32	40	50
d	16	20	25	32	40	50	63
A	45	45	53,5	54	62	78	87
B	39,5	39,5	51	51	63,5	72	84
C	33	33	40	43	51	56	64
D	55,5	55,5	62	70	84	101	115
E	5,5	5,5	5,5	6,5	6,5	6,5	6,5
F	34	34	36	38	40	45	50
H	126	126	137	139,5	159,5	167	175,5
L	97,5	107	128,5	135,5	155	181	206,5
P	98	98	102	102	105	105	105
Q	64	64	64	64	74	74	74
R	70	70	70	70	75	75	75
s	1,8	1,9	2,3	2,9	3,7	4,6	5,8
t	12,5	13	15	18	20	26	30
PN	16	16	16	16	16	16	16

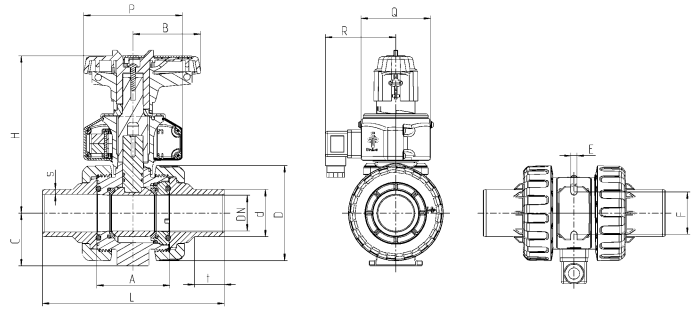

Connector type

PVC-U fix flange DIN-ANSI-JIS

(dimensions in mm)

DN	15	20	25	32	40	50
d	20	25	32	40	50	63
A	45	53,5	54	62	78	87
B	39,5	51	51	63,5	72	84
C	33	40	43	51	56	64
E	5,5	5,5	6,5	6,5	6,5	6,5
F	34	36	38	40	45	50
H	126	137	139,5	159,5	167	175,5
P	98	102	102	105	105	105
Q	64	64	64	74	74	74
R	70	70	70	75	75	75
I	97	105	125	140	150	165
L1	130	150	160	180	200	230
PN	16	16	16	16	16	16

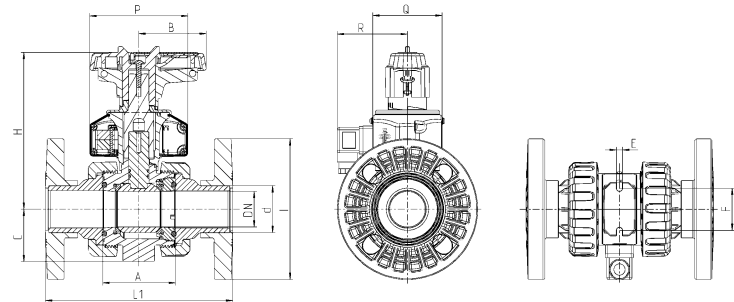

Dimensions position feedback

Connector type fix flange DIN-ANSI-JIS

(dimensions in mm)

standard	DN	15	20	25	32	40	50
	d	20	25	32	40	50	63
	inch	3/4"	1"	1 1/4"	1 1/2"	2"	2 1/2"
DIN 2501	b	14	14	14	18	18	18
	Z	65	75	85	100	110	125
ANSI Class 150	b	15,5	15,5	15,5	15,5	15,5	19
	Z	60,3	69,8	79,3	89	98,5	120,6
JIS 10 k	b	15	15	19	19	19	19
	Z	70	75	90	100	105	120

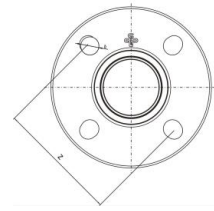

Connector type PVC-U backing flange DIN

(dimensions in mm)

DN	15	20	25	32	40	50
d	20	25	32	40	50	63
inch	1/2"	3/4"	1"	1 1/4"	1 1/2"	2"
A	45	53,5	54	62	78	87
B	395	51	51	53,5	72	84
b	14	14	14	18	18	18
C	33	40	43	51	56	64
E	5,5	5,5	6,5	6,5	6,5	6,5
F	34	36	38	40	45	50
H	126	137	139,5	159,5	167	175,5
I	97	105	125	140	150	165
L1	129,5	149,5	159,5	178,5	200	228,5
LK	65	75	85	100	110	125
P	98	102	102	105	105	105
Q	64	64	64	74	74	74
R	70	70	70	75	75	75
PN	10	10	10	10	10	10

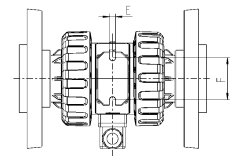
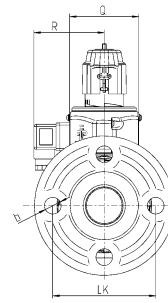
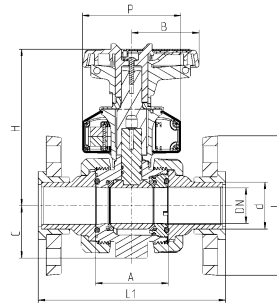

Exploded drawing position feedback

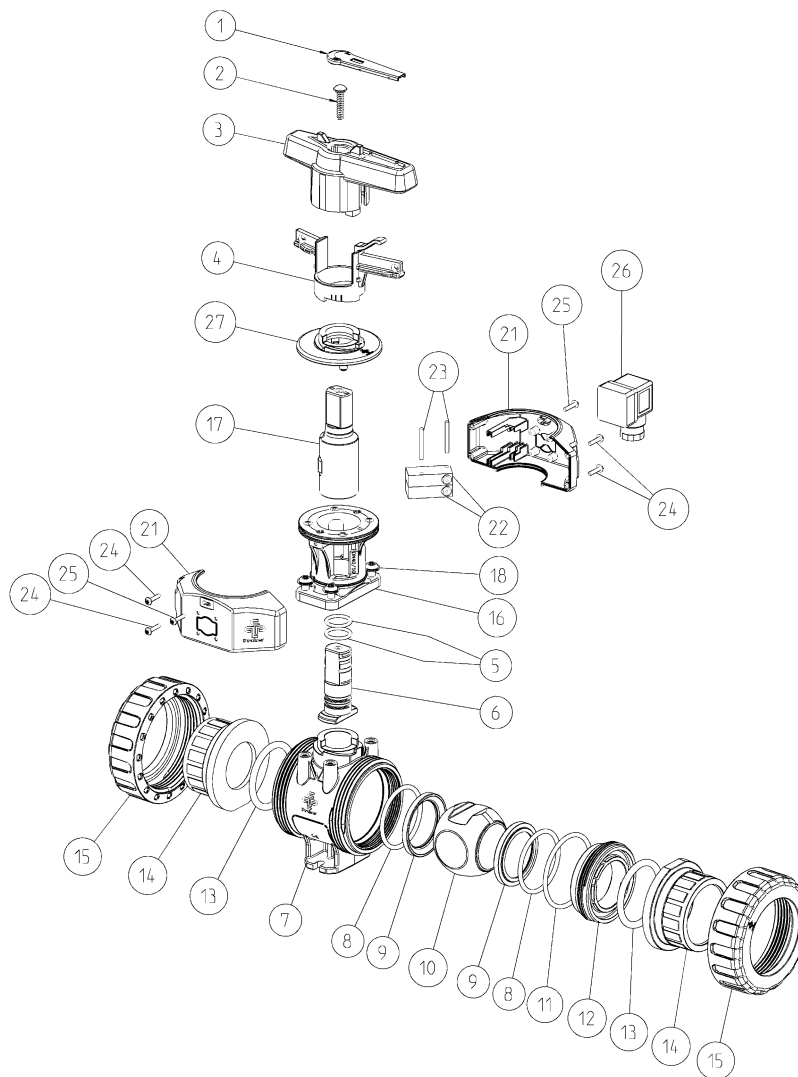

No.	Description	Material	No.	Description	Material
01.	Labeling plate	PBT	15.	Union nut	PVC-U
02.	Screw	A2	16.	bracket	PA-GF
03.	Handle	PP-GF	17.	Coupling shaft	PA-GF
04.	Spring loaded locking sleeve	PBT	18.	Screw	A2
05.	O-ring	EPDM / FPM	19.	Screw	A2
06.	Shaft	PVC-U	20.	Toothed washer	A2
07.	Body	PVC-U	21.	Half shells	ABS
08.	O-ring	EPDM / FPM	22.	Limit switch IP67	-
09.	Ball seating joint	PTFE	23.	Pin	A2
10.	Ball	PVC-U	24.	Screw	A2
11.	O-ring	EPDM / FPM	25.	Locking scfew	A2
12.	Thrust collar	PVC-U	26.	Device plug IP65	-
13.	O-ring	EPDM / FPM	27.	Cover	ABS
14.	Connector types				
	Solvent socket /-spigot	PVC-U			
	Threaded socket	PVC-U			
	Fusion socket /-spigot	PE100			
	Flange	PVC-U			

Technical data position feedback

Limit switch mechanical		
Type	(Ag-Ni) NO/NC*	(Au) NO*/NC*
Voltage max.	15-250V AC (15-30V DC)	5-250V AC (5-30V DC)
Current max.	100mA-5A	1mA-3A
Protection limit switch	IP67	
Protection DIN-plug	IP65	
Ambient temperature	-10°C bis +50°C	
Electric wiring	NO	NC
A pressed ... open		
B pressed... closed		

* on request

Limit switch inductive		
Type	NPN*/PNP	NAMUR EMV acc. IEC / EN 60947-5-2:2004; NE 21 DIN EN 60947-5-6
Voltage max.	10-30V DC	8V DC
Current max.	0-100mA	NAMUR intrinsically safe
Protection limit switch	IP67	
Protection DIN-plug	IP65	
Ambient temperature	-10°C bis +50°C	
Electric wiring		

* on request

Dimensions electric EO 510

Connector type

PVC-U solvent socket metric / ASTM

(dimensions in mm)

DN	10	15	20	25
d	16	20	25	32
inch	3/8"	1/2"	3/4"	1"
A	45	45	53,5	54
C	33	33	40	43
D	55,5	55,5	62	70
E	5,5	5,5	5,5	6,5
F	34	34	36	38
H	80	80	85,5	88
t	16	16,5	19,5	23
Z	51	50	59,5	60
PN	16	16	16	16
actuator	EO510 ECO/IND			
B	239	239	251,5	257
J	49,5	49,5	49,5	49,5
K	102,5	102,5	102,5	102,5
M	77	77	77	77
N	93	93	93	93

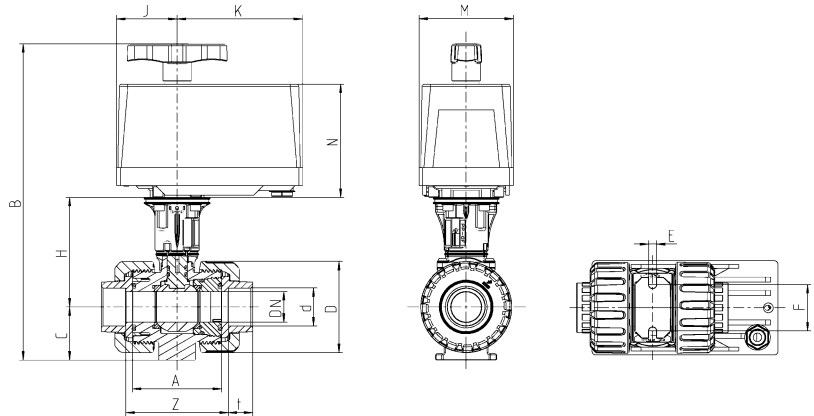

Connector type

PVC-U solvent spigot metric

(dimensions in mm)

DN	10	15	20	25
d	16	20	25	32
A	45	45	53,5	54
C	33	33	40	43
D	55,5	55,5	62	70
E	5,5	5,5	5,5	6,5
F	34	34	36	38
H	80	80	85,5	88
L	98	123,5	143,5	153,5
s	2,8	2	2,5	3,5
t	17	17	20,5	23,5
PN	16	16	16	16
actuator	EO510 ECO/IND			
B	239	239	251,5	257
J	49,5	49,5	49,5	49,5
K	102,5	102,5	102,5	102,5
M	77	77	77	77
N	93	93	93	93

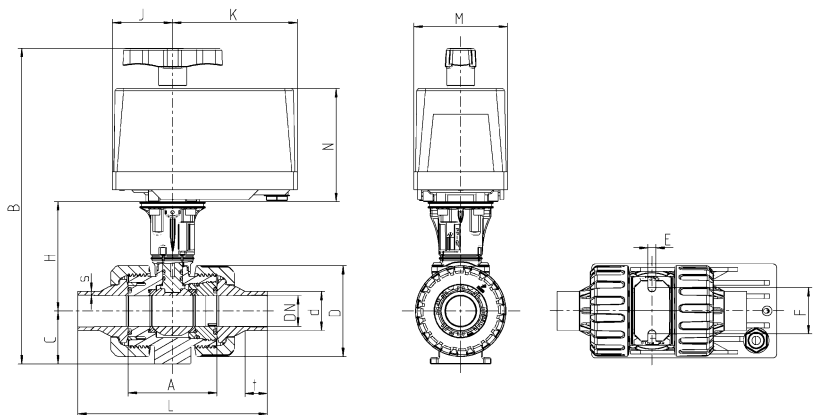

Dimensions electric EO 510

Connector type

PVC-U threaded socket BSP / NPT

(dimensions in mm)

DN	10	15	20	25
d	16	20	25	32
inch	3/8"	1/2"	3/4"	1"
A	45	45	53,5	54
C	33	33	40	43
E	5,5	5,5	5,5	6,5
F	34	34	36	38
D	55,5	55,5	62	70
H	80	80	85,5	88
t	17	17	19,5	23
Z	51	50	59,5	60
PN	16	16	16	16
actuator	EO510 ECO/IND			
B	239	239	251,5	257
J	49,5	49,5	49,5	49,5
K	102,5	102,5	102,5	102,5
M	77	77	77	77
N	93	93	93	93

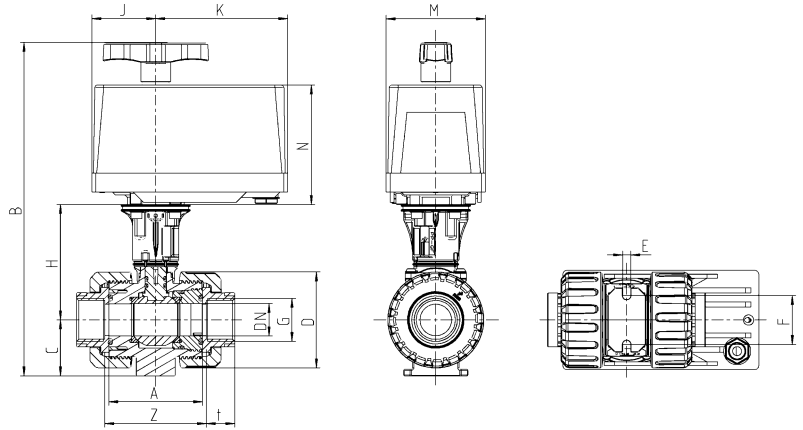

Connector type

PVC-U fix flange DIN-ANSI-JIS

(dimensions in mm)

DN	15	20	25
d	20	25	32
A	45	53,5	54
C	33	40	43
E	5,5	5,5	6,5
F	34	36	38
H	80	85,5	88
I	97	105	125
L1	130	150	160
PN	16	16	16
actuator	EO510 ECO/IND		
B	239	251,5	257
J	49,5	49,5	49,5
K	102,5	102,5	102,5
M	77	77	77
N	93	93	93

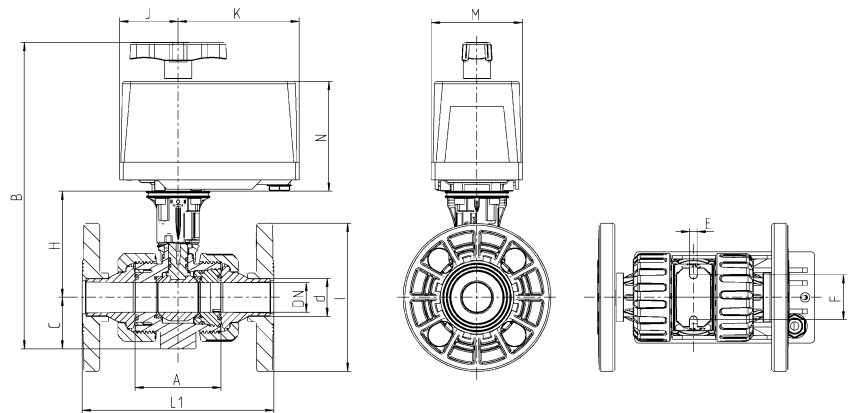

Exploded drawing electric EO 510

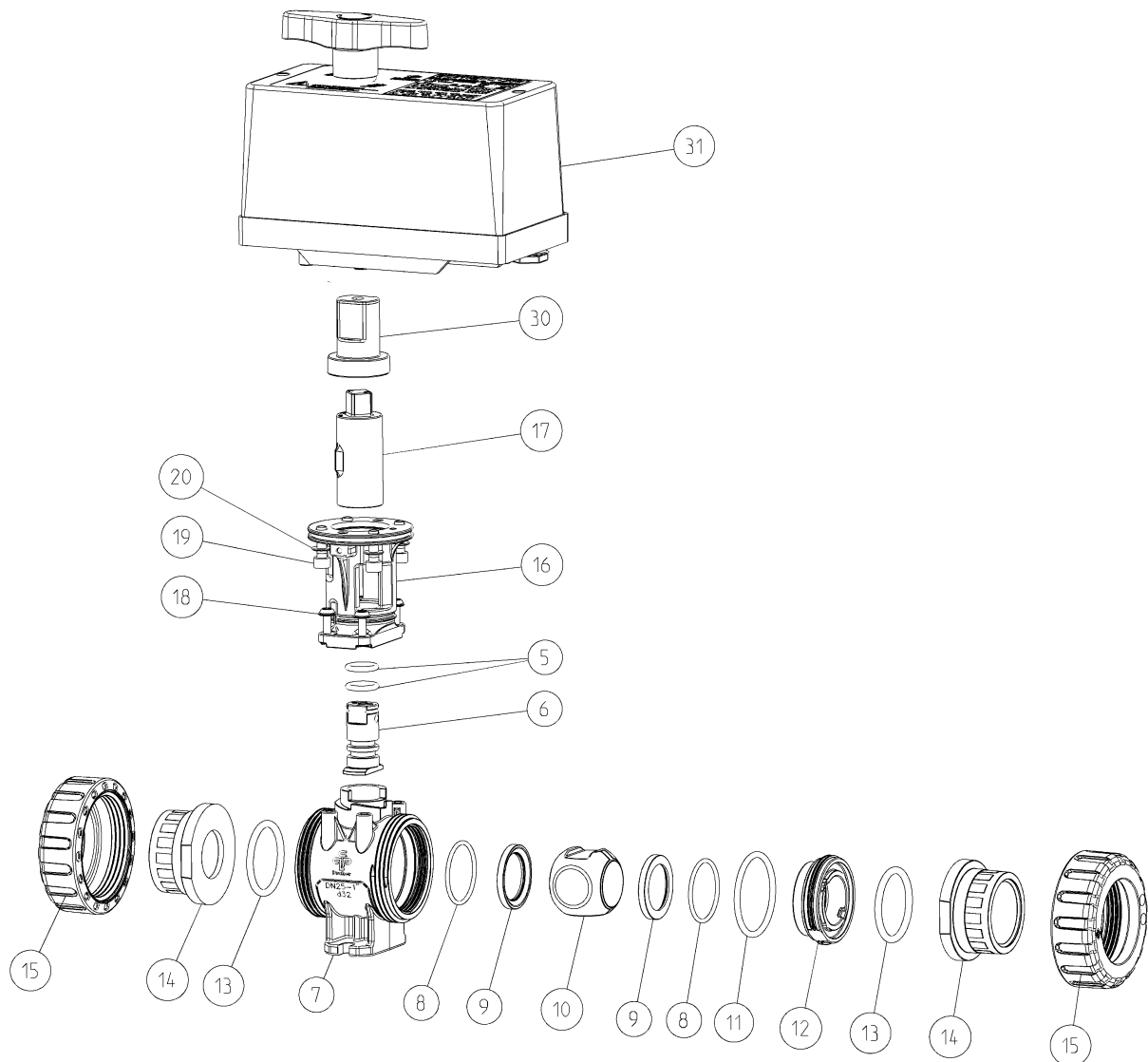

No.	Description	Material	No.	Description	Material
05.	O-ring	EPDM / FPM	15.	Union nut	PVC-U
06.	Shaft	PVC-U	16.	Bracket	PA-GF
07.	Body	PVC-U	17.	Coupling shaft	PA-GF
08.	O-ring	EPDM / FPM	18.	Screw	A2
09.	Ball seating joint	PTFE	19.	Screw	A2
10.	Ball	PVC-U	20.	Toothed washer	A2
11.	O-ring	EPDM / FPM	30.	Coupling	PA-GF
12.	Thrust collar	PVC-U	31.	Actuator EO 510	-
13.	O-ring	EPDM / FPM			
14.	Connector types				
	Solvent socket /-spigot	PVC-U			
	Threaded socket	PVC-U			
	Fusion socket /-spigot	PE100			
	Flange	PVC-U			

Technical data electric EO 510

electric actuator EO510		
Type	E0510 ECO-230	E0510 IND-24
Nominal torque	7 Nm	
Peak torque	9 Nm	
Voltage	230V AC	12 - 24V DC / 24V AC
Frequency range	50 / 60Hz	DC / 50 / 60HZ
Operating time	22 sec 90°	12 sec 90°
Power consumption	4W	
Rotation angle	360° adjusted to 90°	
Duty cycle	60% / max. 20 min	
Protection	IP65	
Ambient temperature	0°C bis + 50°C	
Weight	0,7 kg	
Position indicator	optically (manual override handle)	
Manual override	integrated	

Electrical connection:

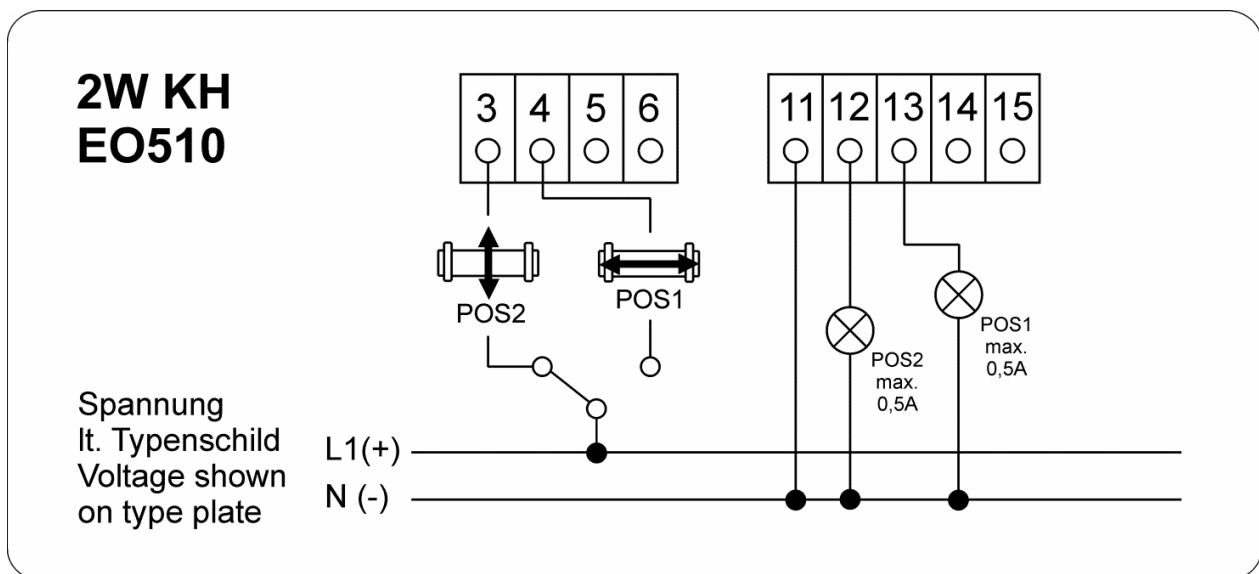

Dimensions electric EO ER

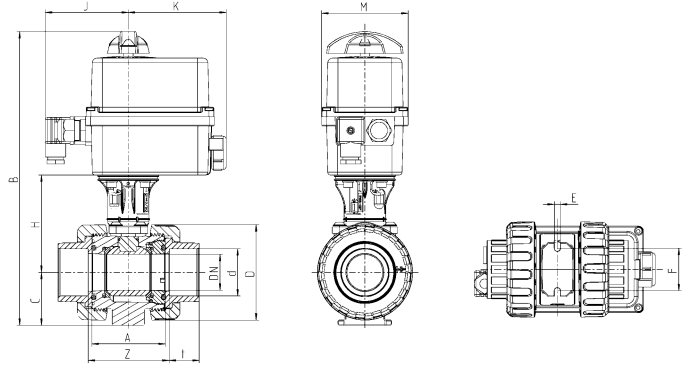

Connector type

PVC-U solvent socket metric/ASTM (up to DN50)

(dimensions in mm)

DN	10	15	20	25	32	40	50	65	80	80
d	16	20	25	32	40	50	63	75	90	110
inch	3/8"	1/2"	3/4"	1"	1 1/4"	1 1/2"	2"	2 1/2"	3"	4"
A	45	45	53,5	54	62	78	87	111,5	135,5	135,5
C	33	33	40	43	51	56	64	85	100	100
D	55,5	55,5	62	70	84	101	115	149	182	182
E	5,5	5,5	5,5	6,5	6,5	6,5	6,5	8,3	10,3	10,3
F	34	34	36	38	40	45	50	65	80	80
H	80	80	85,5	88	97	103	109,5	136,5	159,5	159,5
t	16	16,5	19,5	23	26,5	31,5	38,5	44,5	56,5	61
Z	51	50	59,5	60	68,5	86	98	122	152,5	162
PN	16	16	16	16	16	16	16	16	16	16
actuator	ER20							ER60		
B	265	265	277,5	283	300	311	325,5	398	436,5	436,5
J	90	90	90	90	90	90	90	98	98	98
K	107	107	107	107	107	107	107	107	107	107
M	92	92	92	92	92	92	92	128	128	128

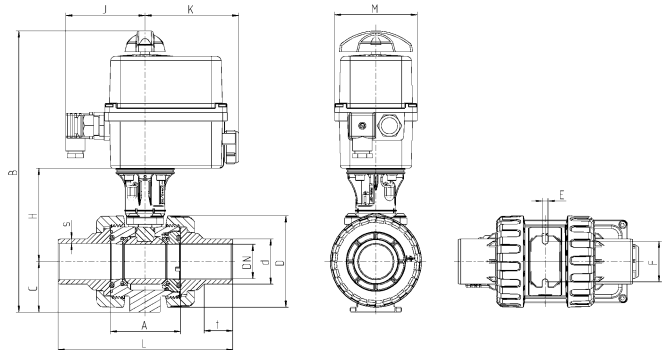

Connector type

PVC-U solvent spigot metrisch

(dimensions in mm)

DN	10	15	20	25	32	40	50
d	16	20	25	32	40	50	63
A	45	45	53,5	54	62	78	87
C	33	33	40	43	51	56	64
D	55,5	55,5	62	70	84	101	115
E	5,5	5,5	5,5	6,5	6,5	6,5	6,5
F	34	34	36	38	40	45	50
H	80	80	85,5	88	97	103	109,5
L	98	123,5	143,5	153,5	173,5	194	223
s	2,8	2	2,5	3,5	4	5	6,5
t	17	17	20,5	23,5	27	32	40
PN	16	16	16	16	16	16	16
actuator	ER20						
B	265	265	277,5	283	300	311	325,5
J	90	90	90	90	90	90	90
K	107	107	107	107	107	107	107
M	92	92	92	92	92	92	92

Dimensions electric EO ER

Connector type

PVC-U threaded socket BSP / NPT

(dimensions in mm)

DN	10	15	20	25	32	40	50
inch	3/8"	1/2"	3/4"	1"	1 1/4"	1 1/2"	2"
A	45	45	53,5	54	62	78	87
C	33	33	40	43	51	56	64
E	5,5	5,5	5,5	6,5	6,5	6,5	6,5
F	34	34	36	38	40	45	50
D	55,5	55,5	62	70	84	101	115
H	80	80	85,5	88	97	103	109,5
t	17	17	19,5	23	26	31,5	38,5
Z	51	50	59,5	60	68,5	86	98
PN	16	16	16	16	16	16	16
actuator	ER20						
B	265	265	277,5	283	300	311	325,5
J	90	90	90	90	90	90	90
K	107	107	107	107	107	107	107
M	92	92	92	92	92	92	92

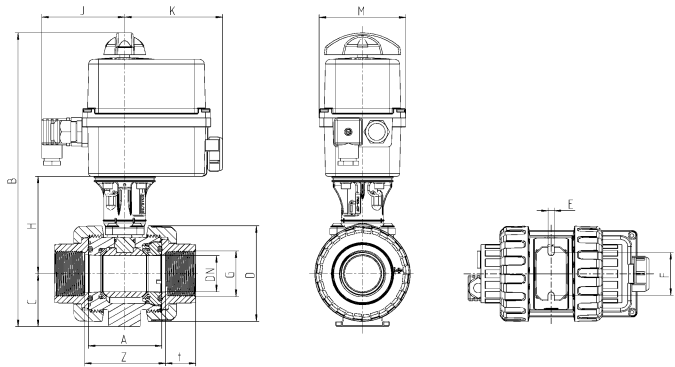

Connector type

PE fusion socket metrisch

(dimensions in mm)

DN	10	15	20	25	32	40	50
d	16	20	25	32	40	50	63
A	45	45	53,5	54	62	78	87
C	33	33	40	43	51	56	64
E	5,5	5,5	5,5	6,5	6,5	6,5	6,5
F	34	34	36	38	40	45	50
D	55,5	55,5	62	70	84	101	115
H	80	80	85,5	88	97	103	109,5
t	14,5	16	17	19	21,5	25	29,5
Z	52,5	50	53	64,5	75	97	110,5
PN	16	16	16	16	16	16	16
actuator	ER20						
B	265	265	277,5	283	300	311	325,5
J	90	90	90	90	90	90	90
K	107	107	107	107	107	107	107
M	92	92	92	92	92	92	92

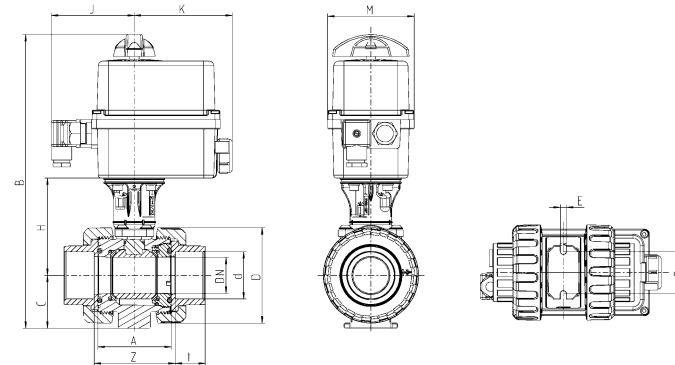

Dimensions electric EO ER

Connector type

PE fusion spigot metric

(dimensions in mm)

DN	10	15	20	25	32	40	50
d	16	20	25	32	40	50	63
A	45	45	53,5	54	62	78	87
C	33	33	40	43	51	56	64
D	55,5	55,5	62	70	84	101	115
E	5,5	5,5	5,5	6,5	6,5	6,5	6,5
F	34	34	36	38	40	45	50
H	80	80	85,5	88	97	103	109,5
L	97,5	107	128,5	135,5	155	181	206,5
s	1,8	1,9	2,3	2,9	3,7	4,6	5,8
t	12,5	13	15	18	20	26	30
PN	16	16	16	16	16	16	16
actuator	ER20						
B	265	265	277,5	283	300	311	325,5
J	90	90	90	90	90	90	90
K	107	107	107	107	107	107	107
M	92	92	92	92	92	92	92

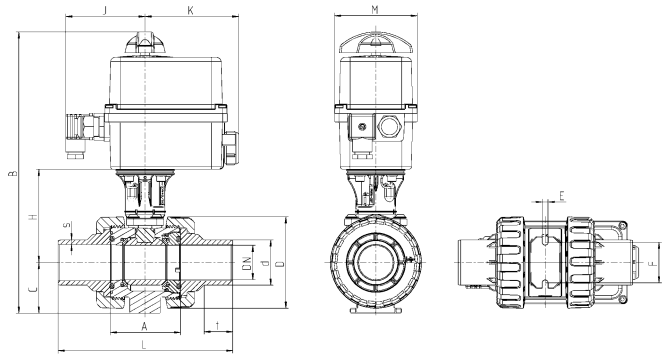

Connector type

PVC-U fix flange DIN-ANSI-JIS

(dimensions in mm)

DN	15	20	25	32	40	50	65	80	80
d	20	25	32	40	50	63	75	90	110
A	45	53,5	54	62	78	87	111,5	135,5	135,5
C	33	40	43	51	56	64	85	100	100
E	5,5	5,5	6,5	6,5	6,5	6,5	8,3	10,3	10,3
F	34	36	38	40	45	50	65	80	80
H	80	85,5	88	97	103	109,5	136,5	159,5	159,5
I	97	105	125	140	150	165	185	200	229
L1	130	150	160	180	200	230	266	307,5	324,5
PN	16	16	16	16	16	16	16	16	16
actuator	ER20						ER60		
B	265	277,5	283	300	311	325,5	398	436,5	436,5
J	90	90	90	90	90	90	98	98	98
K	107	107	107	107	107	107	107	107	107
M	92	92	92	92	92	92	128	128	128

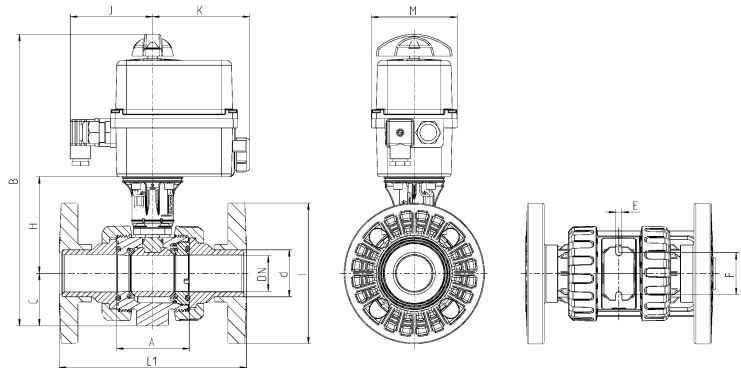

Dimensions electric EO ER

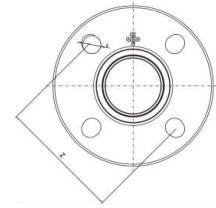

Connector type fix flange DIN-ANSI-JIS (dimensions in mm)

standard	DN	15	20	25	32	40	50	65	80	80
	d	20	25	32	40	50	63	75	90	110
	inch	1/2"	3/4"	1"	1 1/4"	1 1/2"	2"	2 1/2"	3"	4"
DIN 2501	b	14	14	14	18	18	18	18	18	18
	Z	65	75	85	100	110	125	145	160	180
ANSI Class 150	b	15,5	15,5	15,5	15,5	15,5	19	19	19	19
	Z	60,3	69,8	79,3	89	98,5	120,6	139,7	152,4	190,5
JIS 10 k	b	15	15	19	19	19	19	19	19	19
	Z	70	75	90	100	105	120	140	150	175

Connector type PVC-U backing flange DIN (dimensions in mm)

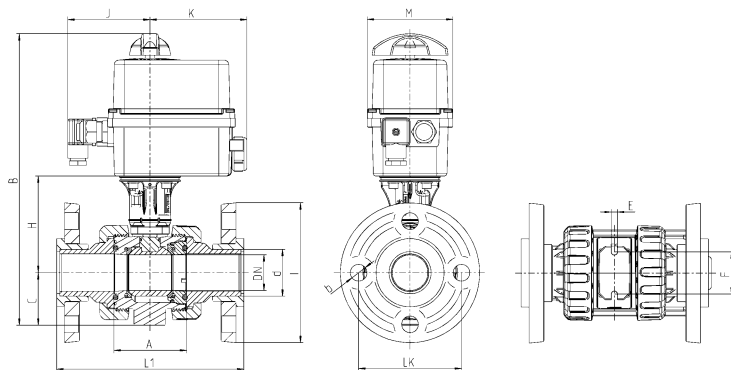

DN	15	20	25	32	40	50	65	80	80	
d	20	25	32	40	50	63	75	90	110	
A	45	53,5	54	62	78	87	111,5	135,5	135,5	
b	14	14	14	18	18	18	18	18	18	
C	33	40	43	51	56	64	85	100	100	
E	5,5	5,5	6,5	6,5	6,5	6,5	8,5	10,3	10,3	
F	34	36	38	40	45	50	65	80	80	
H	80	85,5	88	97	103	109,5	136,5	159,5	159,5	
I	97	105	125	140	150	165	185	200	229	
L1	129,5	149,5	159,5	178,5	200	228,5	266	307,5	324,5	
LK	65	75	85	100	110	125	145	160	180	
PN	10	10	10	10	10	10	10	10	10	
actuator	ER20					ER60				
B	265	277,5	283	300	311	325,5	398	436,5	436,5	
J	90	90	90	90	90	90	98	98	98	
K	107	107	107	107	107	107	107	107	107	
M	92	92	92	92	92	92	128	128	128	

Exploded drawing electric EO ER

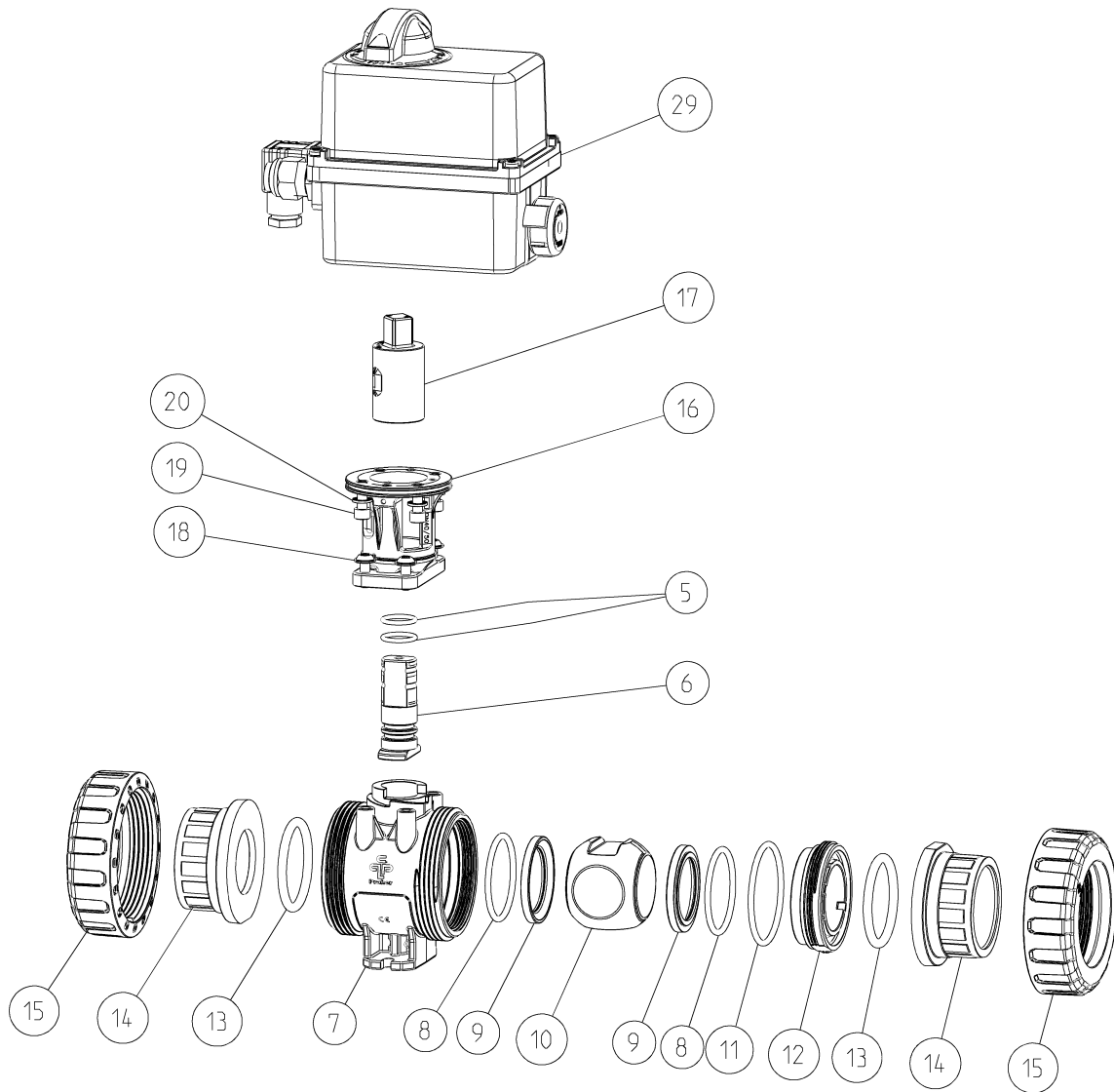

No.	Description	Material	No.	Description	Material
05.	O-ring	EPDM / FPM	15.	Union nut	PVC-U
06.	Shaft	PVC-U	16.	bracket	PA-GF
07.	Body	PVC-U	17.	Coupling shaft	PA-GF
08.	O-ring	EPDM / FPM	18.	screw	A2
09.	Ball seating joint	PTFE	19.	screw	A4
10.	Ball	PVC-U	20.	Toothed washer	A2 / A4 from DN65
11.	O-ring	EPDM / FPM	29.	Actuator	-
12.	Thrust collar	PVC-U		Premier / Posi / Failsafe	
13.	O-ring	EPDM / FPM			
14.	Connector types				
	Solvent socket /-spigot	PVC-U			
	Threaded socket	PVC-U			
	Fusion socket /-spigot	PE100			
	Flange	PVC-U			

Technical data electric EO ER

electric actuator		
Type	ER20	ER60
Torque	20 Nm	60 Nm
Voltage	<p>Premier 24V 50/60Hz (24V DC) 100 - 240V 50/60Hz (100 - 350V DC)</p> <p>Posi 15 - 30V AC 50/60 Hz (12V - 48V DC) 100V - 240V AC 50/60 Hz (100 - 230V DC)</p> <p>Failsafe 15 - 30V AC 50/60 Hz (24V - 48V DC) 100V - 240V AC 50/60 Hz (100 - 230V DC)</p>	<p>Premier 24V 50/60Hz (24V DC) 90 - 240V 50/60Hz (90 - 350V DC)</p> <p>Posi 15 - 30V AC 50/60 Hz (12V - 48V DC) 100V - 240V AC 50/60 Hz (100 - 230V DC)</p> <p>Failsafe 15 - 30V AC 50/60 Hz (24V - 48V DC) 100V - 240V AC 50/60 Hz (100 - 230V DC)</p>
Operating time	<p>Premier: 13s Failsafe / Posi: 11s</p>	<p>Premier: 15s Failsafe / Posi: 12s</p>
Power	15W	45W
ISO flange	F03-F04-F05	F05-F07
Star drive nut	14	22
Rotation angle	90°	90°
Duration duty	30%	50%
Protection	<p>Premier: IP65 Failsafe / Posi: IP66</p>	
Ambient temperature	<p>Premier / Posi: -10°C bis +55°C Failsafe: -10°C bis +40°C</p>	
Weight	1 kg	2,1 kg

Dimensions pneumatic

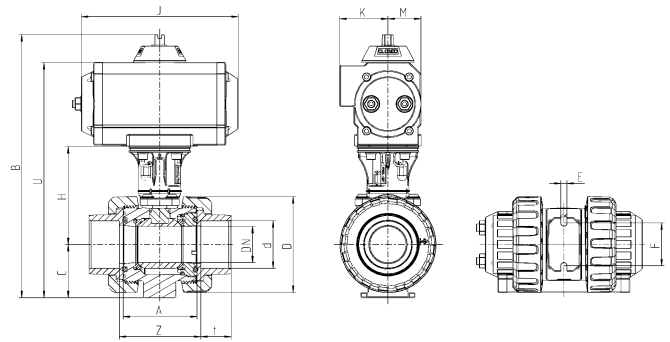

Connector type

PVC-U solvent socket metric / ASTM (up to DN50)

(dimensions in mm)

DN	10	15	20	25	32	40	50	65	80	80
d	16	20	25	32	40	50	63	75	90	110
inch	3/8"	1/2"	3/4"	1"	1 1/4"	1 1/2"	2"	2 1/2"	3"	4"
A	45	45	53,5	54	62	78	87	111,5	135,35	135,5
C	33	33	40	43	51	56	64	85	100	100
D	55,5	55,5	62	70	84	101	115	149	182	182
E	5,5	5,5	5,5	6,5	6,5	6,5	6,5	8,3	10,3	10,3
F	34	34	36	38	40	45	50	65	80	80
H	80	80	85,5	88	97	103	109,5	136,5	159,5	159,5
t	16	16,5	19,5	23	26,5	31,5	38,5	44,5	56,5	61
Z	51	50	59,5	60	68,5	86	98	122	152,5	162
PN	16	16	16	16	16	16	16	16	16	16
actuator	UT05DA*				UT15DA			UT20DA		
B	214	214	226,5	232	269	280	294,5	364,5	402,5	402,5
J	119	119	119	119	165	165	165	178	178	178
K	40	40	40	40	50	50	50	53	53	53
M	27	27	27	27	35	35	35	43	43	43
U	184	184	196,5	202	239	250	264,5	334,5	372,5	372,5
actuator	UT05SR**				UT15SR		UT17SR	UT30SR	UT35SR	
B	214	214	226,5	232	269	280	294,5	383,5	455	455
J	119	119	119	119	165	165	197	230	246	246
K	40	40	40	40	50	50	50	61,5	72,5	72,5
M	27	27	27	27	35	35	35	52	65,5	65,5
U	184	184	196,5	202	239	250	264,5	354	426	426

*DA ... double acting (PO-DA)

**SR ... spring return (PO-NC / PO-NO)

We recommend using a damper and supporting the actuator accordingly when installing the valve in a vertical position
Additional information and dimensions for solenoid valve and position feedback see accessories and spare parts

Dimensions pneumatic

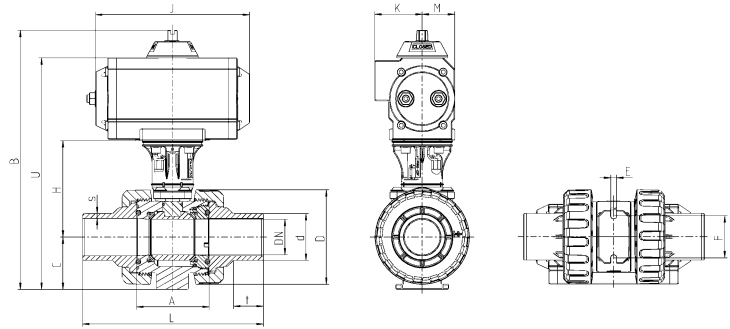

Connector type

PVC-U solvent spigot metric

(dimensions in mm)

DN	10	15	20	25	32	40	50
d	16	20	25	32	40	50	63
A	45	45	53,5	54	62	78	87
C	33	33	40	43	51	56	64
D	55,5	55,5	62	70	84	101	115
E	5,5	5,5	5,5	6,5	6,5	6,5	6,5
F	34	34	36	38	40	45	50
H	80	80	85,5	88	97	103	109,5
L	98	123,5	143,5	153,5	173,5	194	223
s	2,8	2	2,5	3,5	4	5	6,5
t	17	17	20,5	23,5	27	32	40
PN	16	16	16	16	16	16	16
actuator	UT05DA				UT15DA		
B	214	214	226,5	232	269	280	294,5
J	119	119	119	119	165	165	165
K	40	40	40	40	50	50	50
M	27	27	27	27	35	35	35
U	184	184	196,5	202	239	250	264,5
actuator	UT05SR			UT15SR		UT17SR	
B	214	214	226,5	232	269	280	294,5
J	119	119	119	119	165	165	197
K	40	40	40	40	50	50	50
M	27	27	27	27	35	35	35
U	184	184	196,5	202	239	250	264,5

*DA ... double acting (PO-DA)

**SR ... spring return (PO-NC / PO-NO)

We recommend using a damper and supporting the actuator accordingly when installing the valve in a vertical position
Additional information and dimensions for solenoid valve and position feedback see accessories and spare parts

Dimensions pneumatic

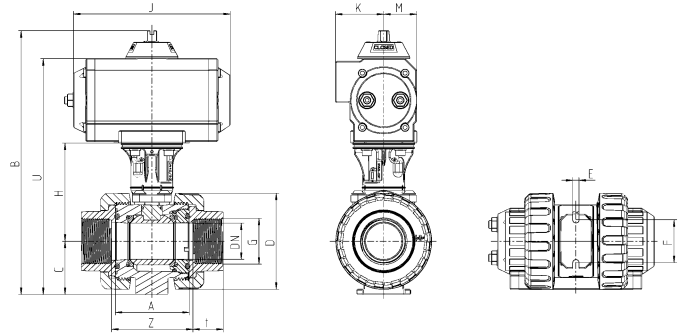

Connector type

PVC-U threaded socket BSP / NPT

(dimensions in mm)

DN	10	15	20	25	32	40	50
inch	3/8"	1/2"	3/4"	1"	1 1/4"	1 1/2"	2"
A	45	45	53,5	54	62	78	87
C	33	33	40	43	51	56	64
D	55,5	55,5	62	70	84	101	115
E	5,5	5,5	5,5	6,5	6,5	6,5	6,5
F	34	34	36	38	40	45	50
H	80	80	85,5	88	97	103	109,5
t	16	16,5	19,5	23	26,5	31,5	38,5
Z	51	50	59,5	60	68,5	86	98
PN	16	16	16	16	16	16	16
actuator	UT05DA				UT15DA		
B	214	214	226,5	232	269	280	294,5
J	119	119	119	119	165	165	165
K	40	40	40	40	50	50	50
M	27	27	27	27	35	35	35
U	184	184	196,5	202	239	250	264,5
actuator	UT05SR				UT15SR		UT17SR
B	214	214	226,5	232	269	280	294,5
J	119	119	119	119	165	165	197
K	40	40	40	40	50	50	50
M	27	27	27	27	35	35	35
U	184	184	196,5	202	239	250	264,5

*DA ... double acting (PO-DA)

**SR ... spring return (PO-NC / PO-NO)

We recommend using a damper and supporting the actuator accordingly when installing the valve in a vertical position
Additional information and dimensions for solenoid valve and position feedback see accessories and spare parts

Dimensions pneumatic

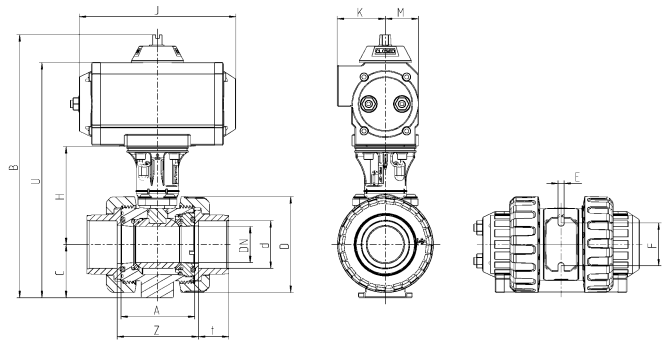

Connector type

PE fusion socket metric

(dimensions in mm)

DN	10	15	20	25	32	40	50
d	16	20	25	32	40	50	63
A	45	45	53,5	54	62	78	87
C	33	33	40	43	51	56	64
D	55,5	55,5	62	70	84	101	115
E	5,5	5,5	5,5	6,5	6,5	6,5	6,5
F	34	34	36	38	40	45	50
H	80	80	85,5	88	97	103	109,5
t	14,5	16	17	19	21,5	25	29,5
Z	52,5	50	62	64,5	75	97	110,5
PN	16	16	16	16	16	16	16
actuator	UT05DA				UT15DA		
B	214	214	226,5	232	269	280	294,5
J	119	119	119	119	165	165	165
K	40	40	40	40	50	50	50
M	27	27	27	27	35	35	35
U	184	184	196,5	202	239	250	264,5
actuator	UT05SR			UT15SR		UT17SR	
B	214	214	226,5	232	269	280	294,5
J	119	119	119	119	165	165	197
K	40	40	40	40	50	50	50
M	27	27	27	27	35	35	35
U	184	184	196,5	202	239	250	264,5

*DA ... double acting (PO-DA)

**SR ... spring return (PO-NC / PO-NO)

We recommend using a damper and supporting the actuator accordingly when installing the valve in a vertical position
Additional information and dimensions for solenoid valve and position feedback see accessories and spare parts

Dimensions pneumatic

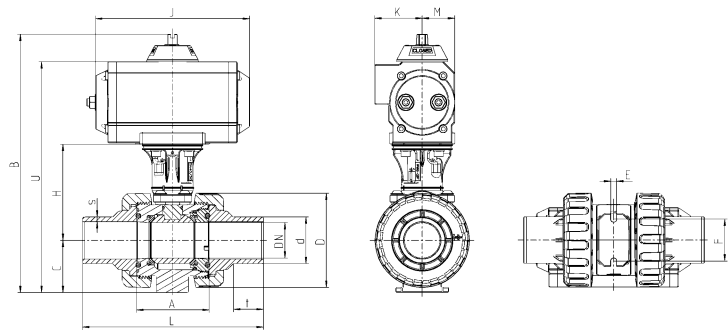

Connector type

PE fusion socket metric

(dimensions in mm)

DN	10	15	20	25	32	40	50
d	16	20	25	32	40	50	63
A	45	45	53,5	54	62	78	87
C	33	33	40	43	51	56	64
D	55,5	55,5	62	70	84	101	115
E	5,5	5,5	5,5	6,5	6,5	6,5	6,5
F	34	34	36	38	40	45	50
H	80	80	85,5	88	97	103	109,5
L	97,5	107	128,5	135,5	155	181	206,5
s	1,8	1,9	2,3	2,9	3,7	4,6	5,8
t	12,5	13	15	18	20	26	30
PN	16	16	16	16	16	16	16
actuator	UT05DA				UT15DA		
B	214	214	226,5	232	269	280	294,5
J	119	119	119	119	165	165	165
K	40	40	40	40	50	50	50
M	27	27	27	27	35	35	35
U	184	184	196,5	202	239	250	264,5
actuator	UT05SR				UT15SR	UT17SR	
B	214	214	226,5	232	269	280	294,5
J	119	119	119	119	165	165	197
K	40	40	40	40	50	50	50
M	27	27	27	27	35	35	35
U	184	184	196,5	202	239	250	264,5

*DA ... double acting (PO-DA)

**SR ... spring return (PO-NC / PO-NO)

We recommend using a damper and supporting the actuator accordingly when installing the valve in a vertical position
Additional information and dimensions for solenoid valve and position feedback see accessories and spare parts

Dimensions pneumatic

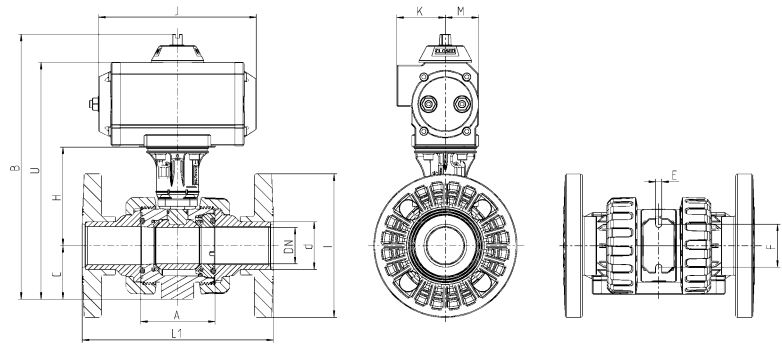

Connector type

PVC-U fix flange DIN-ANSI-JIS

(dimensions in mm)

DN	15	20	25	32	40	50	65	80	80
d	20	25	32	40	50	63	75	90	110
A	45	53,5	54	62	78	87	111,5	135,35	135,5
C	33	40	43	51	56	64	85	100	100
E	5,5	5,5	6,5	6,5	6,5	6,5	8,3	10,3	10,3
F	34	36	38	40	45	50	65	80	80
H	80	85,5	88	97	103	109,5	136,5	159,5	159,5
I	97	105	125	140	150	165	185	200	229
L1	130	150	160	180	200	230	266	307,5	324,5
PN	16	16	16	16	16	16	16	16	16
actuator	UT05DA			UT15DA			UT20DA		
B	214	226,5	232	269	280	294,5	364,5	402,5	402,5
J	119	119	119	165	165	165	178	178	178
K	40	40	40	50	50	50	53	53	53
M	27	27	27	35	35	35	43	43	43
U	184	196,5	202	239	250	264,5	334,5	372,5	372,5
actuator	UT05SR			UT15SR		UT17SR	UT30SR	UT35SR	
B	214	226,5	232	269	280	294,5	383,5	455	455
J	119	119	119	165	165	197	230	246	246
K	40	40	40	50	50	50	61,5	72,5	72,5
M	27	27	27	35	35	35	52	65,5	65,5
U	184	196,5	202	239	250	264,5	354	426	426

*DA ... double acting (PO-DA)

**SR ... spring return (PO-NC / PO-NO)

We recommend using a damper and supporting the actuator accordingly when installing the valve in a vertical position
Additional information and dimensions for solenoid valve and position feedback see accessories and spare parts

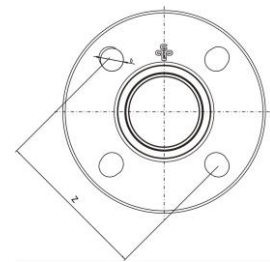

Connector type

fix flange DIN-ANSI-JIS

(dimensions in mm)

	DN	15	20	25	32	40	50	65	80	80
standard	d	20	25	32	40	50	63	75	90	110
	inch	3/4"	1"	1 1/4"	1 1/2"	2"	2 1/2"	3"	4"	3/4"
DIN 2501	b	14	14	14	18	18	18	18	18	18
	Z	65	75	85	100	110	125	145	160	180
ANSI Class 150	b	15,5	15,5	15,5	15,5	15,5	19	19	19	19
	Z	60,3	69,8	79,3	89	98,5	120,6	139,7	152,4	190,5
JIS 10 k	b	15	15	19	19	19	19	19	19	19
	Z	70	75	90	100	105	120	140	150	175

Dimensions pneumatic

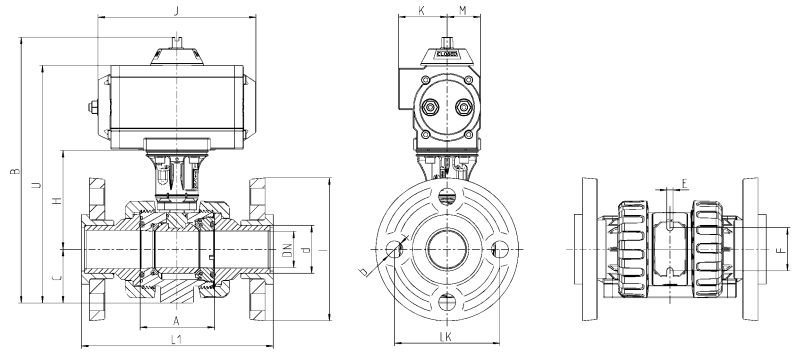

Connector type PVC-U backing flange DIN

(dimensions in mm)

DN	15	20	25	32	40	50	65	80	80
d	20	25	32	40	50	63	75	90	110
A	45	53,5	54	62	78	87	111,5	135,35	135,5
b	14	14	14	18	18	18	18	18	18
C	33	40	43	51	56	64	85	100	100
E	5,5	5,5	6,5	6,5	6,5	6,5	8,3	10,3	10,3
F	34	36	38	40	45	50	65	80	80
H	80	85,5	88	97	103	109,5	136,5	159,5	159,5
I	97	105	125	140	150	165	185	200	229
L1	129,5	149,5	159,5	178,5	200	228,5	265,5	308	325
LK	65	75	85	100	110	125	145	160	180
PN	10	10	10	10	10	10	10	10	10
actuator	UT05DA			UT15DA			UT20DA		
B	214	226,5	232	269	280	294,5	364,5	402,5	402,5
J	119	119	119	165	165	165	178	178	178
K	40	40	40	50	50	50	53	53	53
M	27	27	27	35	35	35	43	43	43
U	184	196,5	202	239	250	264,5	334,5	372,5	372,5
actuator	UT05SR			UT15SR		UT17SR	UT30SR	UT35SR	
B	214	226,5	232	269	280	294,5	383,5	455	455
J	119	119	119	165	165	197	230	246	246
K	40	40	40	50	50	50	61,5	72,5	72,5
M	27	27	27	35	35	35	52	65,5	65,5
U	184	196,5	202	239	250	264,5	354	372,5	372,5

*DA ... double acting (PO-DA)

**SR ... spring return (PO-NC / PO-NO)

We recommend using a damper and supporting the actuator accordingly when installing the valve in a vertical position
Additional information and dimensions for solenoid valve and position feedback see accessories and spare parts

Exploded drawing pneumatic

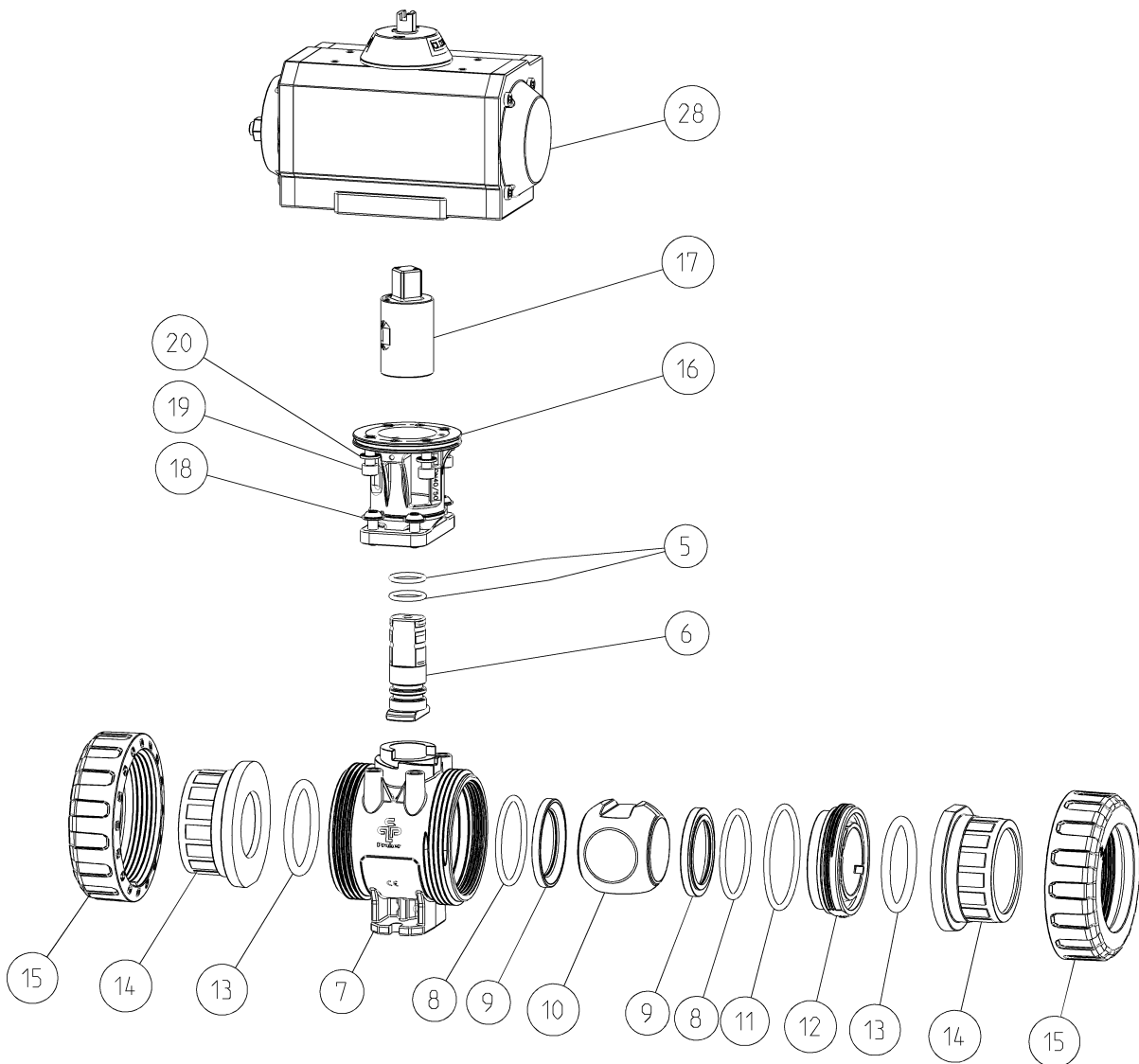

No.	Description	Material	No.	Description	Material
05.	O-ring	EPDM / FPM	15.	Union nut	PVC-U
06.	Shaft	PVC-U	16.	bracket	PA-GF
07.	Body	PVC-U	17.	Coupling shaft	PA-GF
08.	O-ring	EPDM / FPM	18.	Screw	A2
09.	Ball seating joint	PTFE	19.	Screw	A4
10.	Ball	PVC-U	20.	Thoothed washer	A2 / A4 from DN65
11.	O-ring	EPDM / FPM	28.	Actuator	-
12.	Thrust collar	PVC-U			
13.	O-ring	EPDM / FPM			
14.	Connector types				
	Solvent socket /-spigot	PVC-U			
	Threaded socket	PVC-U			
	Fusion socket /-spigot	PE100			
	Flange	PVC-U			

Technical data pneumatic

Technical features of pneumatic actuator

Description actuator:

Piston actuation with two opposed pistons, power transmission with tooth rack, seal elastic

Material actuator:

- o Body: aluminium anodized
- o End caps: aluminium epoxy powder
- o Screws / nuts: stainless steel

Ambient temperature: -20°C to +80°C

Control fluid:

Filtered air according to PNEUROP/ISO class 4 – Thread ¼"

Mounting: in every possible direction

Control function / control pressure:

DA: double acting / max. 10 bar

SR: spring return / max. 8 bar

Rotation angle:

90°; adjustment in both directions from -10° to +10° (UT15 and bigger)

Installation:

- o actuator – valve: ISO 5211
- o actuator – solenoid valve: NAMUR (VDI/VDE 3845)
- o actuator – limit switch box: NAMUR (VDI/VDE 3845)

AIR CONSUMPTION (FULL CYCLE)

DA DOUBLE ACTING

actuator	UT05 DA	UT15 DA	UT20 DA
N. Lt.	0,22	0,41	0,71

AIR CONSUMPTION (FULL CYCLE)

SR SPRING RETURN

actuator	UT05 SR	UT15 SR	UT17 SR	UT30 SR	UT35 SR
N. Lt.	0,13	0,18	0,25	0,65	1,2

Accessories / spare parts

Adapter set for automation electric or pneumatic

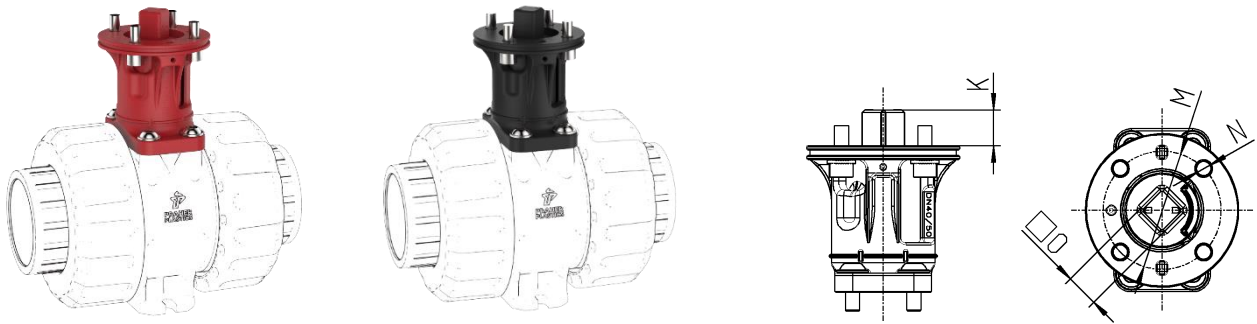

Consist of:

- Bracket for mounting of actuator and position feedback
- Coupling for actuator
- Screws for mounting on ball valve and actuator



dimensions in mm

DN	10	15	20	25	32	40	50	65	80	80
d	16	20	25	32	40	50	63	75	90	110
K	11	11	11	11	15	15	15	18	18	18
M	42	42	42	42	50	50	50	70	70	70
N	5,5	5,5	5,5	5,5	6,5	6,5	6,5	8,5	8,5	8,5
O	11	11	11	11	14	14	14	17	17	17

		
Material	PP-GF	PA-GF
Product line	chemical resistance	high durability
Acid resistance	++	0
Tensile modulus of elasticity	+	++
Flexural modulus of elasticity	+	+++
Notch impact strength (23°C)	+	+
Main applications	Electrolysis Acid applications Chrome, Copper, hydrofluoric acid	Water applications Ultrafiltration Semiconductor industry
Recommended installation	Horizontal	Horizontal Vertical (support the actuator)
Recommended maintenance	Short maintenance intervals	Regular inspections
Recommended accessories	Silencer for pneumatic actuator	
M1 Ball Valve	PVC-U / PP-H / PVDF	
ISO 5211	F04 / F05 / F07	

Accessories / spare parts

Half shell set with position feedback for hand operated and automatic ball valves

Consist of:

- Half shells including limit switch mechanical or inductive
- Device plug
- Screws for half shells
- Locking screws for adjusting position feedback

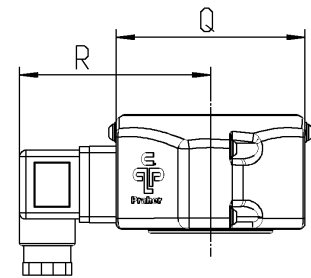
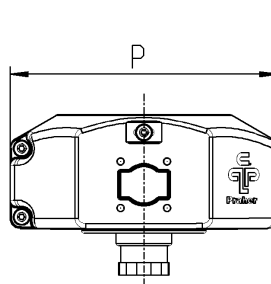
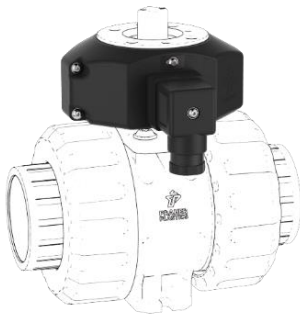

dimensions in mm

DN	10	15	20	25	32	40	50	65	80	80
d	16	20	25	32	40	50	63	75	90	110
P	98	98	102	102	105	105	105	116	116	116
Q	64	64	64	64	74	74	74	99	99	99
R	70	70	70	70	75	75	75	88	88	88

Feedback set for hand operated ball valve DN10 – DN80 d110



Consist of:

- Half shells including limit switch mechanical or inductive
- Cover
- Coupling for handle
- Device plug
- Screws for half shells
- Locking screws for adjusting position feedback
- Screws for mounting on the ball valve

Accessories / spare parts

Feedback set for automatic ball valve DN10 – DN80 d110



Consist of:

- Half shells including limit switch mechanical or inductive
- Coupling for actuator
- Device plug
- Screws for half shells
- Locking screws for adjusting position feedback
- Screws for mounting on the ball valve and actuator

Clamping and spacing element

Use for mounting as a clamping element

- Floor / ceiling / wall
- Plate
- Additional screws necessary

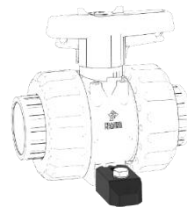

Use for mounting as a spacing element

- for flange connection
- additional screws necessary

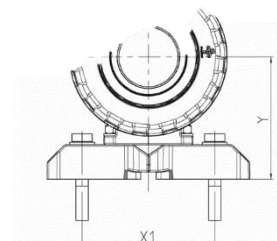
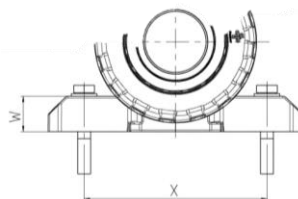
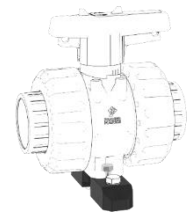

dimensions in mm

DN	10	15	20	25	32	40	50
d	16	20	25	32	40	50	63
T	54	54	54	65	65	65	65
U	25	25	25	32	32	32	32
V	6,5	6,5	6,5	8,5	8,5	8,5	8,5
W	16	16	16	22	22	22	22
X	90	90	94	107	109	114	119
X1	70	70	70	85	85	85	85
Y	49	49	56	65	73	78	86

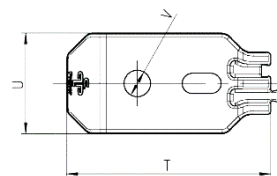

Accessories / spare parts

Union nut locking for ball valve DN10 – DN80 d110

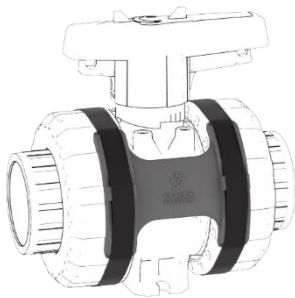

Consist of:

- Plate for PVC-U or PP-H / PVDF ball valve
- Velcro straps for fixation

Cover for ball valve DN10 – DN80 d110

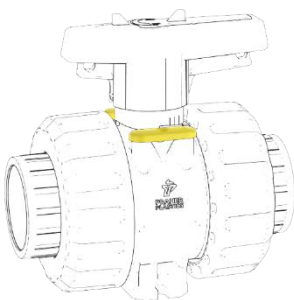

Consist of:

- Cover for PVC-U, PP-H and PVDF ball valve
- Pack unit 50 pieces
- Including eyelet for marking



Pipe clip type B

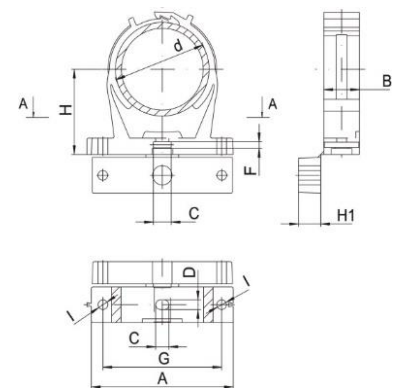

dimensions in mm

d	20 - 23	25 - 28	31 - 35	39 - 43	47 - 51	60 - 65	72 - 80	87 - 95
A	56	61	67	80	84,5	96,5	126	137
B	14	16	16	17,5	20	24	26	26
C	9	9	9	9	9	9	12	12
D	6,5	6,5	6,5	6,5	6,5	6,5	8,5	8,5
F	3,5	3,5	3,5	3,5	3,5	3,5	4,3	4,3
G	41	47	52	64	70	80	106	117
H	27	30	31,5	37	41	49	70	80
H1	6	10	11,5	14	15	15	15	20
I	6,5	6,5	6,5	6,5	6,5	6,5	8,5	8,5

Accessories / spare parts

PLS – Praher Labeling System

Features

- Clear and durable label
- Convenient marking by touch-up pen or laser engraving
- Standard version in yellow, blue, green and red
- Simple and easy to change
- Corrosion-resistant
- No effect on the function of the handle



Limit switch box for pneumatic actuator

General

- Limit switch box with two mechanical switches
- Protection IP65
- Cable gland M20*1,5

Material

- Body: polycarbonat black
- Cover: polycarbonat clear
- Mounting bracket and screws: stainless steel
- Seals: EPDM

Voltage

- 1 – 250V

Current

- 16 A (250V AC)
- 2,5 A (24 DC)

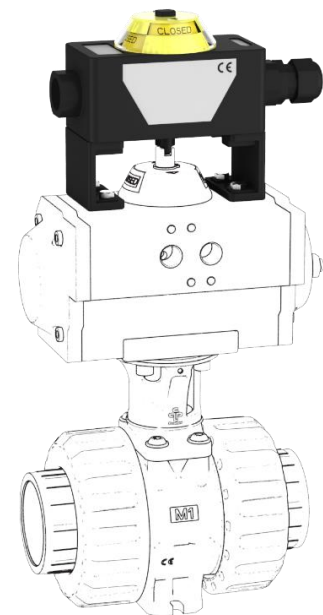

dimensions in mm

A	B	H	X	Y
80	30	110	107	56

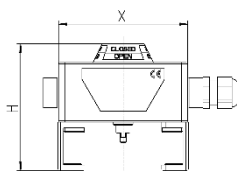
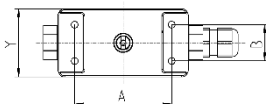

Accessories / spare parts

Solenoid valve

General

- Solenoid valve NAMUR with combined 5/2- and 3/2- ways function and standard coil
- Easy switch from 5/2- to 3/2- ways by turning the sealing plate
- Manual override as standard
- Protection IP65

Material

- Body: aluminium anodized
- Piston: aluminium
- Seals: NBR
- Screws and spring: stainless steel

Voltage

- 24 V DC (3W)
- 230 V AC (5VA)

Accessories

- Flow control silencer
- Silencer

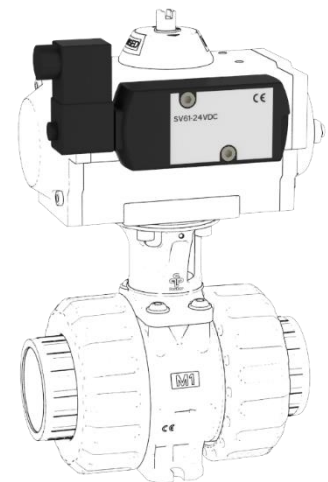

dimensions in mm

A	B	C
139	45	33

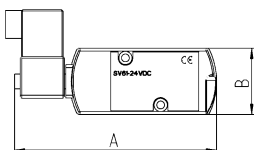

Accessories / spare parts

Handle elongation

Material:	PVC-U
Dimensions:	DN10 – DN80 d110
Standard pipe length:	200 mm
Max. pipe length possible:	1 m

Features

- Simple assembly by gluing the handle- and shaft-coupling with a metric pipe
- Marking on handle- and shaft-coupling for alignment to the ball valve
- Subsequent installation in existing installation possible
- Direction arrows on the handle coupling show the flow direction of the ball valve when handle is removed

Further details see data sheet for handle extension 2W and 3W ball valve

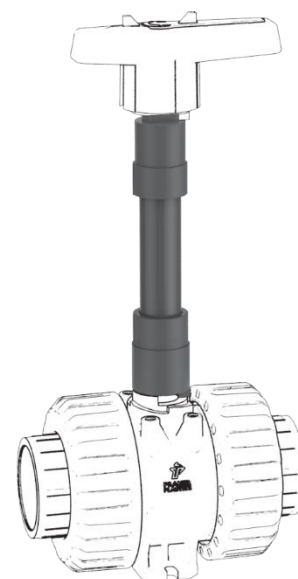

Praher Plastics Austria GmbH

Poneggenstraße 5
4311 Schwertberg
Österreich

T +43 7262 61178-0
F +43 7262 61203
sales@praherplastics.com

M1 Ball Valve Series – Modularity for any
application

<https://youtu.be/aAF5omvfaoM>

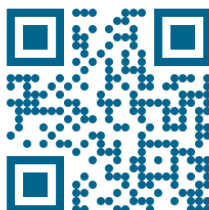

© Praher Plastics Austria GmbH
Zertifiziert nach / certified acc. to
EN ISO 9001:2015

DB/DEEN/21/03/450B

Diese Druckschrift enthält keine
Gewährleistungszusagen, sondern will lediglich
eine erste Information vermitteln. Das Programm
wird ständig erweitert, daher entsprechen die
Ausführungen und Typen dem Stand bei
Drucklegung. Technische Änderungen
vorbehalten!

This document contains no warranties, but
simply conveys initial information. The program
is constantly expanding and therefore the
versions and types correspond to the state on
the date of printing. Subject to technical
changes!

